



PERFORMANCE
TRANSMISSION CONTROLS
& ACCESSORIES





America's Number One Shifter

Known as "America's Number 1 Shifter Company", Hurst proudly maintains a wide variety of quality products for the performance enthusiast. Over the years, Hurst has been the OEM shifter supplier for the Pontiac GTO, Plymouth Barracuda, Plymouth SuperBird, Ford Mustang Boss 302, Oldsmobile and AMC, just to name a few.

When you purchase a Hurst Shifter or accessory, you are receiving a piece of legendary Hurst heritage and quality. From Drag Racing to Street Rods, Circle Track to Street Machines, Hurst manufactures quality-engineered shifters, accessories and transmission products to fit the needs of the performance minded driver.



HURST HEMI UNDER GLASS Die Cast Metal Replica Car Personally Autographed by Bob Riggle

A VERY LIMITED number of HURST HEMI UNDER GLASS 1:64 scale replica cars are available through Hurst, autographed by the original car builder and driver Bob Riggle!

Bob has been driving the rear engine '68 Plymouth Barracuda powered by a 426 Chrysler Hemi for over 35 years at race tracks all over the world, and has agreed to personally sign a limited number of these replicas.

Now out of production, these replicas are from the JOHNNY LIGHTNING SHOWSTOPPER series and are very difficult to obtain. Once our supplies are gone, no more will be available.

Part No. 378 0463



Bob Riggle

CONTENTS



	PAGES
AUTOMATIC SHIFTERS	2 - 11
Accessories	11
Auto/Stick 3	8
Dual Gate	9
Pistol Grip Quarter Stick	5
Pistol Grip Quarter Stick 2	6
ProMatic 2	2
Quarter Stick	4
Quarter Stick 2	6
Street Rod	10
V-Matic 2	3
MANUAL SHIFTERS	12 - 22
Billet/Plus	12
Competition Plus - 4, 5 & 6 Speed	13-18
Mastershift 3 Speed	20-21
Quick/Stick - Compacts	22
Street Super/Shifter 4 Speed	19
Truck	18
INDY SHIFTERS	23 - 25
Automatic	24
Qualifier 3 Speed	25
SSA 3 Speed	25
Truck 3 Speed	24
Universal 4 Speed	23
RACING and SPECIALTY SHIFTERS	26 - 31
Lightening Rods for Lenco's	30
Pro V-Gate 5	29
Richmond 5 Speed	28
Speedway Super/Shifter	31
Super/Shifter 3	27
V-Gate 2 In-Line Shifter	26
SHIFTER/TRANS ACCESSORIES	32 - 39
ATF Fluid	39
Automatic Trans Lock Up Kits	37
Hot Shift Kits	38
Roll/Control, Line/Loc	32
Roll/Control Accessories	32-33
Shifter Boots	36
Shifter Knobs	33-35
T-Handles	33-35
Transmission Swap Kits	39
SERVICE PARTS	40 - 55
Components	40-50
Shifter Assembly Drawings	50
Shifter Sticks	47-49
Trans ID Charts	51-55
PROMOTIONAL ITEMS	56
PACKAGING	57-59
NUMERICAL INDEX	60-62
ADDITIONAL INFORMATION	63
WARRANTY and REBUILD INFORMATION	64





AUTOMATIC SHIFTERS

PRO-MATIC 2™ RATCHET SHIFTERS

The Hurst Pro-Matic 2 Ratchet Action Shifter is quality engineered for years of precise, trouble-free operation. The Pro-Matic 2 gives a custom appearance to any vehicle and is ideal for street or strip performance.

The Pro-Matic 2 for trucks incorporates an extended shifter stick for ease of operation and is designed to fit most pick-up trucks.



#383 8500

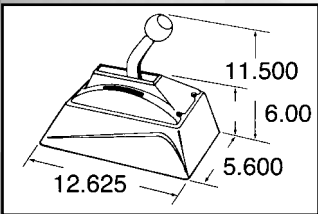

#383 8500



#383 8510

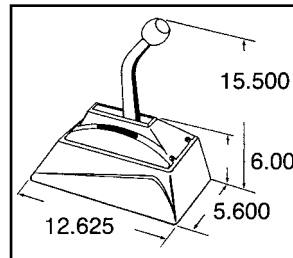

#383 8510



- Full forward and reverse ratchet action can be used with either standard or reverse pattern valve bodies

OPERATION OF SHIFTER FROM PARK:

From the park position, lift up on handle and pull back into reverse. From reverse pull back into neutral, push down and ratchet into gear.

OPERATION OF SHIFTER FROM DRIVE GEAR:

Ratchet into neutral. Pull up on handle and push into reverse. From reverse, pull up on handle and push into park.

- Cable-operated to provide your choice of mounting locations
- Progressively illuminated gear position indicator
- Incorporates a neutral safety and back-up light switch assembly
- Attractive black textured console with chrome-plated top cover can be trimmed to fit any floor contour
- Chrome-plated stick and a black knob (3/8-16 thread) give the shifter a custom look
- Complete with hardware, heavy-duty 5' long shifter cable, and easy to follow installation guide

A P P L I C A T I O N S

Make	Transmission	Trans. Code	CAR	TRUCK
			Part No.	Part No.
GM	TH 250, 350, 375, 400	242, 243	383 8500	383 8510
GM	TH 700 R4 and 200 4R	246, 247	383 8504	383 8511
GM	62-73 Powerglide (Aluminum Case)	245	383 8505	—
Ford	C-4 and C-6	231, 232	383 8500	383 8510
Mopar	Torqueflite A727-A904	221, 222	383 8500	383 8510
AMC	Torque Command A727-A904	221, 222	383 8500	383 8510

GM TURBO 200 ADAPTER KIT PART NO. 117 8580 Permits use of Pro-Matic 2 #383 8500 or V-Matic 2 #383 8520 in GM vehicles w/Turbo Hydromatic 200 (Trans Code 244) Transmission. Kit includes trans arm, cable bracket and required hardware.

AUTOMATIC SHIFTERS

V-MATIC 2™ DUAL MODE SHIFTER



The V-Matic 2 features a dual mode operation for street performance or all out racing.

IN-LINE GATE MODE:

From the park position, pull up on the reverse Loc/Out handle, pull back into reverse, push down and simply pull back into neutral or desired gear.

RATCHET MODE:

From the park position, pull up on the reverse Loc/Out handle and move into reverse. Push down and pull back to neutral. Push down in neutral and ratchet into gear.

- Highly polished shifter lever and brushed aluminum Hurst T-handle (3/8-16 thread).
- Trigger operated reverse Loc/Out approved by NHRA and IHRA.
- Incorporates a neutral safety and back-up light switch assembly.
- Progressively illuminated gear position indicator.
- Attractive black textured console with chrome-plated top cover can be trimmed to fit any floor contour.
- Complete with all hardware, heavy-duty 5' long shifter cable, and easy to follow installation guide.

#383 8520



#383 8515

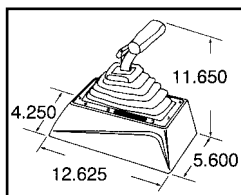

A P P L I C A T I O N S

V-MATIC 2

Make	Transmission	Trans. Code	Part No.
GM	TH 250,350, 400	242, 243	383 8520
GM	TH 700 R4 and 200 4R	246, 247	383 8521
GM	62-73 Powerglide (Aluminum case)	245	383 8525
Ford	C-4 and C-6	231, 232	383 8520
Mopar	Torqueflite A727 and A904	221, 222	383 8520
AMC	Torqueflite A727 and A904	221, 222	383 8520

V-MATIC 2 CONSOLE MODEL

Make	Transmission	Trans. Code	Part No.
Camaro	73-81 TH 250, 350, 375, 400	242, 243	383 8515+
Firebird	70-81 TH 250, 350, 375, 400	242, 243	383 8515+

GM TURBO 200 ADAPTER KIT PART NO. 117 8580 Permits use of Pro-Matic 2 #383 8500 or V-Matic 2 #383 8520 in GM vehicles w/Turbo Hydromatic 200 (Trans Code 244) Transmission. Kit includes trans arm, cable bracket and required hardware + Utilizes factory GM cable, factory back-up light and neutral safety switch. See page 51 for trans code information.



AUTOMATIC SHIFTERS

THE ORIGINAL QUARTER STICK™

The award-winning Quarter Stick Automatic Shifter is designed to provide positive gear change control for street or racing transmission applications.

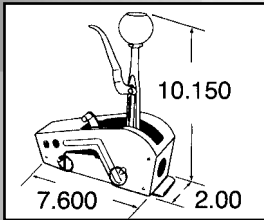

- Designed for 2, 3 and 4-speed automatic transmissions in both forward and reverse valve body shift patterns
- Detent activation is controlled by a chrome-plated trigger contoured to fit comfortably into the driver's hand
- Extremely compact and lightweight for tight fit cockpit installation and weighs only 2.5 pounds
- Comes with factory installed neutral safety switch (back-up light switch is available separately)
- Controlled gate stop activation for positive feel
- One-hand operated, spring loaded reverse Loc/Out mechanism enables drivers to clear the reverse Loc/Out while remaining strapped in their shoulder harness belts
- Comes complete with hardware, 5' long shifter cable, and easy to follow installation guide
- Forged aluminum stick for added strength has 7/16-20 thread
- Optional covers (sold separately) found on page 7



Console models are available for '73-'81 Camaros and '70-'81 Firebirds. Console model Quarter Sticks include a molded escutcheon plate with lighted gear position indicator, neutral safety and back-up light provisions and complete easy to follow installation guide.

A P P L I C A T I O N S

QUARTER STICK

Transmission	Valve Body	Trans. Code	Part No.
Powerglide (Alum. case only)	Forward & Rev.	245	316 0001
TH 250, 350, 375 & 400	Forward	242 & 243	316 0006
TH 250, 350, 375 & 400	Reverse	242 & 243	316 0001
TH 700 R4 & 200 4R	Forward	246 & 247	316 0030
Chrysler/AMC A727, A904	Forward	221, 222	316 0009
Ford C-4, C-6	Forward	231, 236	316 0009
Chrysler/AMC A727, A904	Reverse	221, 222	316 0014
Ford C-4, C-6	Reverse	231, 232	316 0014

QUARTER STICK CONSOLE MODEL

Make	Model	Year	Transmission	Part No.
Chevrolet	Camaro	73-81	TH 200, 350, 375, 400	316 0016
Pontiac	Firebird	70-81	TH 200, 350, 375, 400	316 0016

See page 51 for trans code information

See page 7 for optional Cover Kit kits

See page 46 for heavy-duty cables available in 3 ft., 4 ft., 5 ft., 8 ft., and 11 ft. lengths.

AUTOMATIC SHIFTERS

PISTOL-GRIP QUARTER STICK™

The Hurst Pistol-Grip Quarter Stick Shifter is designed for a firm comfortable natural grip, providing a positive feel when shifting. This shifter has all of the same award winning features and qualities of our existing Quarter Stick automatic shifter, including controlled detent activation, one-hand operated spring loaded reverse Loc/Out mechanism, and neutral safety switch.

The pistol-grip handle is CNC-machined from billet aluminum or exceptional strength, and features a precision snap-action switch that is ideal for operating a Hurst Roll/Control, nitrous system or trans brake.



A P P L I C A T I O N S

PISTOL-GRIP QUARTER STICK

Transmission	Valve Body	Trans. Code	Part No.
Powerglide (Alum. case only)	Forward & Reverse	245	316 2001
GM TH 250, 350, 375 & 400	Forward	242 & 243	316 2006
GM TH 250, 350, 375 & 400	Reverse	242 & 243	316 2001
GM TH 700R4 & 2004R	Forward	246, 247	316 2030
Chrysler/AMC A727, A904	Forward	221, 222	316 2009
Ford C-4, C-6	Forward	231, 236	316 2009
Chrysler/AMC A727, A904	Reverse	221, 222	316 2014
Ford C-4, C-6	Reverse	231, 232	316 2014

QUARTER STICK ACCESSORIES

SOLENOID SHIFTING KIT

The Hurst Electric Solenoid Shifting Kit is designed to automatically complete the 1st to 2nd gear change, increasing shifting reliability and improving E.T. consistency.

- Engineered for forward pattern Hurst Quarter Stick and Pistol-Grip shifters
- Shifting is controlled when used with an rpm activated switch or manually activated push button (normally open) switch.
- The solenoid features a spring activated plunger, and is designed to quickly and firmly push the shifter stick into gear, not "hit" or "slam" it, which can cause damage to the stick itself.
- Kit includes a H.D. 12-volt solenoid rated at maximum 3-amp draw to hold the plunger in position, aluminum mounting bracket, hardware, fuse and electrical connectors.



Part No. 226 0020



AUTOMATIC SHIFTERS

QUARTER STICK 2™ AND PISTOL GRIP 2™

Based on the original Quarter Stick technology, this ultimate drag racing shifter is ideal for rear engine dragsters.

- Rear exit cable for easier installation, positive shifts and less potential cable binding
- Designed for 2 and 3-speed transmissions in both forward and reverse valve body shift patterns
- Comes complete with hardware, and 5' long shifter cable, and easy to follow installation guide
- Forged aluminum stick for added strength has 7/16-20 thread (Quarter Stick)
- Other features are the same as the Quarter Stick Automatic Shifter
- Shown with optional cover 130 0056 (sold separately) found on page 7



#316 0020

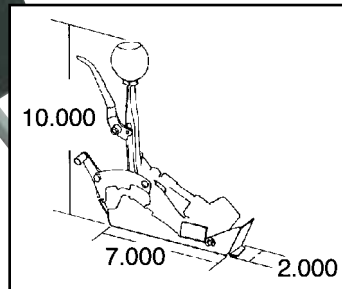

#316 2020

QUARTER STICK SHIFT GATE PATTERNS



Powerglide



Turbo Hydra Forward

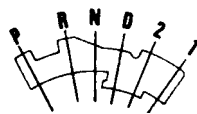

Chrysler, Ford, AMC Forward

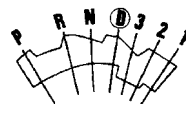

Turbo Hydra 4-Speed

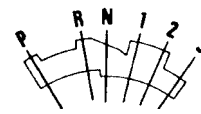

Turbo Hydra Reverse



Chrysler, Ford, AMC Reverse

A P P L I C A T I O N S

Transmission	Valve Body	Trans. Code	QUARTER STICK 2	PISTOL GRIP 2
			Part No.	Part No.
Powerglide	Forward and Reverse	245	316 0020	316 2020
TH 250, 350, 375 & 400	Reverse	242 & 243	316 0020	316 2020
TH 250, 350, 375 & 400	Forward	242 & 243	316 0025	316 2025

See page 7 for optional Cover Kits.
See page 51 for trans code information

QUARTER STICK ACCESSORIES



ALUMINUM COVER KIT

Adds a professional finished look to your Quarter Stick or Pistol Grip installation. Attaches to shifter with quick release pins (included) and may be used in conjunction with the aluminum mounting plate kit. Does not fit Quarter Stick 2 or Pistol Grip 2.

Part No.	Description
130 0041	Aluminum Cover
189 0082	Replacement Pins



PLASTIC COVER KIT

Adds a distinctive finished look to your Quarter Stick™ installation. Mounting plate and button head screws are included with the plastic cover kit.

Part No.	Application
130 0055	Quarter Stick/Pistol Grip
130 0056	Quarter Stick 2/Pistol Grip 2



ALUMINUM MOUNTING PLATE KIT

Clear anodized aluminum mounting plate offers mounting flexibility and allows quick shifter removal via quick release pins (included).

Part No.	Description
195 0225	Mounting Plate
189 0082	Replacement Pins



NEUTRAL/PARK START SAFETY SWITCH

Kit includes switch and mounting hardware. Easy installation for all existing Quarter Sticks. (Newer Quarter Sticks and Pistol Grip shifters feature the switch installed from the factory.) Fits front and rear exit cable shifters.

Part No.	Description
248 8600	Neutral Safety Switch

BACK-UP LIGHT SWITCH

Kit includes back-up light switch and hardware. Easy installation for all Quarter Sticks and Pistol Grips.

Part No.	Description
248 8601	Back-up light switch



COMPETITION SHIFTER KNOB WITH BUILT-IN 12 V SWITCH

Now with snap action for instant activation, this black molded ABS knob is ideal for use with Hurst Roll/Control®, trans brake, nitrous oxide systems or other 12 volt accessories.

Part No.	Thread Size	Application
163 0050	7/16 x 20	Quarter Stick and Lightning Rods for Lenco's



T-HANDLE WITH BUILT-IN 12-VOLT SWITCH

The ideal command switch for use with Hurst Roll/Control, trans brakes, nitrous oxide systems or other 12 volt accessories. Now with new snap action button and switch for instant activation. Available in brushed aluminum finish only.

Part No.	Thread Size	Application
153 8510	7/16 x 20	Quarter Stick



AUTOMATIC SHIFTERS

AUTO/STICK 3™

An attractive and high-style, cable-operated ratchet type floor shifter for popular automatic transmissions. Designed for high performance racing applications, yet equally at home on the street.



#383 0012

- Delivers short precise gear changes through an exclusive dual pattern ratchet gear selector
- Operates both forward and reverse valve bodies, plus ratchet into neutral feature
- Ratchet mechanism may be overridden to reach any gear by pulling the stick up and moving it to desired position
- Sturdy black console with anodized aluminum trim plate and embossed with the familiar Hurst logo
- Includes bright chrome-plated stick and brushed aluminum T-handle (3/8-16 thread) for added comfort and control
- Incorporates a neutral safety and back-up light switch assembly
- Progressively illuminated gear position indicator.
- Complete with hardware, heavy-duty 5' shifter cable, and easy to follow installation guide

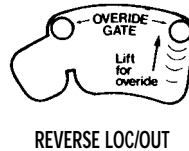
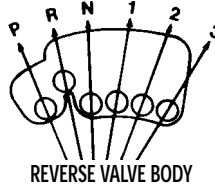
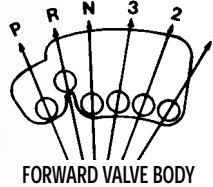
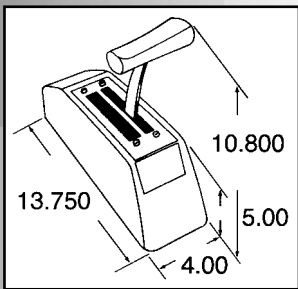

A P P L I C A T I O N S

AUTO/STICK 3

Make	Transmission	Trans. Code	Part No.
GM	TH 200, 250, 350, 375, 400	242, 243, 244	383 0012
Chrysler	Torqueflite A727-A904	221, 222	383 0012
Ford	C-4 and C-6	231, 232	383 0012
AMC	Torque Command A727-A904	221, 222	383 0012

See page 51 for trans code information.

AUTOMATIC SHIFTERS

DUAL/GATE 2™



Hurst's original dual function Gate-Type performance automatic floor shifter is now available to enthusiasts in a universal mount or a direct factory console bolt-in model.

- Contains both street and race gates to control either forward or reverse valve bodies
- Cable operation makes it ideal for street rods and other floorshift conversions
- Illuminated shift pattern indicator
- Attractive black textured console and chrome-plated trim plate with embossed Hurst logo
- Complete with hardware and an easy to follow installation guide
- Chrome-plated stick has 3/8-16 thread



Mechanically, the Dual/Gate 2 contains both street and race gates to control either forward or reverse valve bodies. The street gate duplicates stock factory shift sequence, while the race gate lets you control the gears manually, with fixed gate stops to help prevent overshifts. To change from street to race gate, activate the spring loaded access door and move the shift stick into neutral and over to the right or race gate side of the shifter. A custom fit Dual/Gate 2 is also available, designed to fit factory consoles in '73-'81 Camaros, '83-'92, and '70-'81 Firebirds.



NOTE: Includes one switch that can be used for either a back-up light switch or neutral safety switch.

SHIFT PATTERNS



REVERSE VALVE BODY



FORWARD VALVE BODY



#292 0000

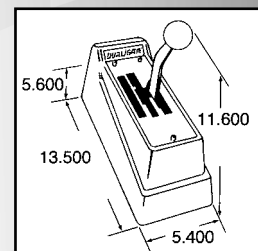

APPLICATIONS

DUAL/GATE 2

Make	Transmission	Trans. Code	Part No.
GM	TH 200, 250, 350, 375, 400	242, 243, 244	292 0006
Chrysler	Torqueflite A727-A904	221, 222	292 0007
Ford	C-4 and C-6	231, 232	292 0007
AMC	Torque Command A727-A904	221, 222	292 0007

DUAL/GATE 2 FACTORY CONSOLE MODELS

Make	Model	Year	Transmission	Trans. Code	Part No.
Chevrolet	Camaro	73-81	TH 200, 250, 350, 375, 400	242, 243, 244	292 0001*
Chevrolet	Camaro	83-92	TH 700 R4 and 200 4R	246, 247	292 0000*
Pontiac	Firebird	70-81	TH 200, 250, 350, 375, 400	242, 243, 244	292 0001*

See page 51 for trans code information.

*Uses stock transmission cable.



AUTOMATIC SHIFTERS

STREET ROD SHIFTER

The Street Rod shifter is designed and quality-built by "America's Number One Shifter Company". Considering Hurst's reputation for reliability, it's no wonder why street rodders worldwide choose the Street Rod Shifter for their vehicles.



- Positive detent activation
- Built-in neutral/park start safety switch
- Rear mount shifter features a machined billet aluminum handle with an attractive billet knob for that hi-tech look
- Forward mount shifter utilizes a chrome-plated bent stick and black knob for the car that has a "Resto" look
- All shifters come complete with mounting brackets, linkage rod, installation hardware and detailed instruction sheet

#383 5690 FORWARD MOUNT

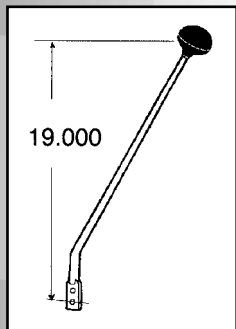

#383 5680 REAR MOUNT

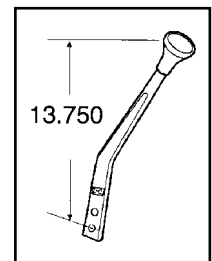

A P P L I C A T I O N S

STREET ROD SHIFTER

Transmission	Forward Mount with Chrome Resto-Style Stick	Rear Mount with Aluminum Handle
TH 200/350/400	383 5690	383 5680
TH 700R4	383 5691	383 5681

ACCESSORIES

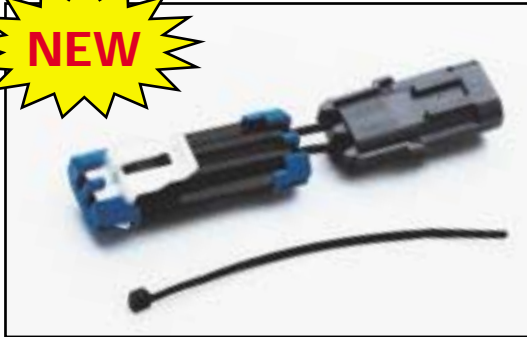

C.A.G.S. SKIP SHIFT ELIMINATOR KIT

A must for any performance enthusiast, the C.A.G.S. (computer aided gear selector) Skip Shift Eliminator Kit eliminates the annoying 1st to 4th mandatory gear change which occurs under pre-set engine rpm and mph conditions. This kit allows full 1st thru 6th gear changes at any speed, rpm or throttle position for maximum performance acceleration on vehicles having the 6-speed transmission. Easily installed and OBD II compatible.

Make/Model	Year	Trans.	Part No.
Chevrolet Camaro & Pontiac Firebird	92-01	BW T-56	155 0100
Chevrolet Corvette	92-96	ZF6	155 0100
Chevrolet Corvette	97	BW T-56	155 0100
Chevrolet Corvette	98-01	BW T-56	155 0120



ADJUSTABLE VACUUM MODULATOR

This modulator is adjustable, allowing you to tailor shift points within a range of 2-4 mph. Comes adjusted for normal shift points. Fits GM TH 350/400 Transmissions. Part No. 650 0001

Note: Adequate engine vacuum is required in order for the modulator to work properly. Inadequate vacuum can result in late or hard shifts.



BACK-UP LIGHT SWITCH

This switch is designed to be used in conjunction with the OEM back-up lights and the Competition/Plus 4-Speed, Super/Shifter 3 and the Master Shift 3-Speed shifters. Part No. 248 0003



DOWNSHIFT SWITCH FOR GM TH 400

Designed to activate the electrically controlled GM TH 400 downshift, this kit is required when replacing a TH 700 R4, TH 200, or TH 350 transmission having a cable-operated downshift mechanism. Universal in design, the switch can easily be adjusted to provide precise control of the downshift timing. Installation is simple, as it uses the stock, OEM bracketry. The kit includes a heavy duty 12 volt switch, actuator rod, spring, and a detailed instruction sheet. Part No. 248 8605



REMOTE TRANSMISSION OIL FILTER KIT

Increases automatic transmission oil capacity and filtration efficiency to give added protection against failure. Remote kit allows oil filter to be mounted in an easily accessible location for quick filter changes. Includes aluminum die cast remote filter base, fittings, hose clamps, mounting hardware, and a premium quality oil filter. Part No. 359 1000



COLUMN SHIFT CONVERSION AID FOR GM TRANSMISSIONS

For column shift conversion with GM TH 350, GM TH 400, GM 200 4R, and GM TH 700 R4, this transmission arm can be used in place of the Hurst #105 0080 making an easy connection to stock back drive rod, thus activating the neutral safety switch and the back-up lights. This eliminates the task of finding the correct wires to splice into. Note: Cannot be used on Pro-Matic 2, V-Matic 2 or Dual Gate. Part No. 105 0059



MANUAL SHIFTERS

BILLET/PLUS™

Hurst Billet/Plus Shifters incorporate a high ratio pivot mechanism for reduced shifter throw and are sturdily constructed for a more positive precise feel when shifting. Self centering alignment improves 2nd to 3rd up-shift gear changes to reduce the chance of "missed shifts". Patented adjustable bias spring loads on most models allow stick tension to be tailored to drivers preference. Dedicated applications assure a custom fit and eliminate any vehicle modifications for ease of installation.



- CNC machined 6061 T-6 BILLET ALUMINUM base and stop collar
- Heat treated BILLET STEEL gear selector for ultimate strength
- High strength steel stick. NOT A CASTING!
- Adjustable positive gear stops to help prevent internal transmission damage
- Stainless steel rotating pivot insures smooth shifting and reduced wear
- Polymide pivot cup reduces stick vibration and noise transfer
- Self centering alignment for improved 2nd to 3rd upshift gear changes
- Patented adjustable bias spring load for ease of operation
- Exclusive oil control seal, on most models, to eliminate trans fluid loss and protect against contamination
- US Patent no. 4,581,951



A P P L I C A T I O N S

BILLET/PLUS SHIFTER

Make/Model	Year	Engine	Transmission	Trans Code	Stick Finish	Part No.
Camaro/Firebird	83-92	V6/V8	BW T-5	464	B	391 5032**
Camaro/Firebird	93-01	V6	BW T-5	464	B	391 5032**
Camaro/Firebird	93-01	V8	BW T-56	468	B	391 5060
Camaro/Firebird	93-01	V8	BW T-56	468	C	391 5061
NEW Corvette C5	97-01	V8	BW T-56		B	391 5085
Corvette C4	89-96	V8	ZF6		B	391 5084
Mustang	83-93	V6/V8	BW T-5	465	B	391 5030
Mustang	94-01	V6/V8	BW T-5 , T-45	465	B	391 5031
Mustang	83-93		Tremec 3550	469	B	391 5070
Mustang	83-98	V8	BW T56 (aftermarket)		B	391 5072
NEW Mustang	2001	V8	Tremec 3650		B	391 5035
Thunderbird/Cougar	83-91	V6/V8	BW T-5	465	B	391 5031
NEW Ranger*	88-00	4-CYL.	5 speed manual		C	391 5020
NEW Ranger*	88-00	V6	5 speed manual		C	391 5021
NEW F-150*	88-96	5.0L	5 speed manual		C	391 5025
Dodge Dakota*	94-99	V6	AX 15		C	391 5050
Dodge Dakota*	90-96	I-4	AX 15		C	391 5050
Jeep Wrangler*	90-98	I-6	AX-15		C	391 5040
Jeep CJ-Series*	82-86	I-6	BW T4/T5		C	391 5045
NEW Jeep Cherokee*	89-99	I-6	AX-15		C	391 5042

* Will not fit vehicles with body lift ** Supplied with 7/16-20 threaded knob

Stick Finish: B = Black, C = Chrome. Chrome sticks supplied with 3/8-16 threaded knob.

Black stick finish has OE factory thread except as noted. See page 55 for trans code information

MANUAL SHIFTERS

COMPETITION/PLUS™ 4, 5 & 6-SPEED



The industry standard for over 30 years, this shifter offers state of the art transmission control for popular 4, 5 & 6-speed manual transmissions. Dedicated applications assure a custom fit to a wide variety of vehicles having factory consoles without any floor pan modifications.

- Race track proven design and reliability.
- Heat treated linkage rods and arms for added strength and durability.
- Adjustable gear stops prevent overshifts to help prolong transmission life.
- Bolt-on chrome-plated stick with attractive custom white knob.
- Complete with all hardware and easy to follow installation guide.

#391 3780 Shifter
#373 8609 Installation Kit



Shifter assembly and installation kit each sold separately.

Optional Hurst Super Boot & plate #114 7494 recommended for finished appearance. See page 36 for other boot styles available.

See pages 14-17 for Competition/Plus Application information

#391 6848 Shifter
#373 7834 Installation Kit





APPLICATIONS

COMPETITION/PLUS™

Model	Year	Description	Trans(3) Code	Transmission	Shifter Only	Installation Kit
BUICK						
GRAN	65	w & w/o Console	451	Muncie	391 7308	373 3163
SPORT	66-67	w & w/o Console	441	Saginaw	391 7307	373 4297
SKYLARK	65	w & w/o Console	451	Muncie	391 7308	373 3163
SPECIAL	66-67	w & w/o Console	441	Saginaw	391 7307	373 4297
CHEVROLET						
FULL SIZE	55-57	All	410	BW T-10	391 3780	373 4734
FULL SIZE	55-57	All	454	RICHMOND/BW T-10	391 3780	373 8609
FULL SIZE	55-57	All	452/453	MUNCIE	391 3780	373 7834
FULL SIZE	55-57	All	441	SAGINAW	391 3780	373 7919
FULL SIZE	55-57	All	451	MUNCIE	391 3780	373 3163
FULL SIZE	58-59	All	410	BW T-10	391 7307	373 3157
FULL SIZE	60-63	w & w/o Console	410	BW T-10	391 7308	373 4734
FULL SIZE	63-64	w & w/o Console	451	MUNCIE	391 7308	373 3163
CAMARO	67-68	w & w/o Console	441	SAGINAW	391 4339	373 4531
CAMARO	67-68	w & w/o Console	451	MUNCIE	391 4339	373 4529
CAMARO	69	w & w/o Console	452	MUNCIE	391 7438	373 7437
CAMARO	70-72	w & w/o Console	453	MUNCIE	391 6848	373 7897
CAMARO	73-74	w/Console	453	MUNCIE	391 8791	373 8605
CAMARO	73-77	w/Console	441	SAGINAW	391 7438	373 8607
CAMARO	74-81	w/o Console	454	BW	391 8794	373 8609
CAMARO	74-81	w/Console	454	BW	391 8791	373 8609
CAMARO	82	w/Console	455	BW T-10(TT)	391 7960	373 0021
CAMARO	82	w/Console	456	SAGINAW(TT)	391 7960	373 0022
CAMARO	83-92	V6/V8	464	BW T-5	391 5032 (1) Billet/Plus	(6)
CAMARO	93-01	V6	464	BW T-5	391 5032 (1) Billet/Plus	(6)
CAMARO	93-01	V8	468	BW T-56	391 5060 (4) Billet/Plus	(6)
CAMARO	93-01	V8	468	BW T-56	391 5061 (5) Billet/Plus	(6)
CHEVELLE & MALIBU	64-67	w & w/o Console	451	MUNCIE	391 7308	373 3163
CHEVELLE & MALIBU	66-67	w & w/o Console	441	SAGINAW	391 7307	373 4297
CHEVELLE & MALIBU	68	w & w/o Console	451	MUNCIE	391 8014	373 3163
CHEVELLE & MALIBU	68-72	w & w/o Console	441	SAGINAW	391 7930	373 7919
CHEVELLE & MALIBU	69-72	w & w/o Console	452/453	MUNCIE	391 8014	373 7834
CHEVELLE & MALIBU	73-74	w & w/o Console	453	MUNCIE	391 6848	373 7897
CHEVELLE & MALIBU	78-79	w & w/o Console	441	SAGINAW	391 8794	373 0017
CHEVY II & NOVA	64	w & w/o Console	451	MUNCIE	391 7308	373 3163
CHEVY II & NOVA	65-67	w & w/o Console	451	MUNCIE	391 7308	373 4354
CHEVY II & NOVA	68	w/Console	451	MUNCIE	391 4339	373 4529
CHEVY II & NOVA	68	w/o Console	451	MUNCIE	391 6848	373 4529
CHEVY II & NOVA	69-70	w/o Console	452	MUNCIE	391 6848	373 7131
CHEVY II & NOVA	71-73	w/o Console	453	MUNCIE	391 6848	373 7834
CORVETTE	57-62	All	410	BW T-10	391 7535	373 3157
CORVETTE	63-67	All	451	MUNCIE	391 7960	373 3162
CORVETTE	68	All	451	MUNCIE	391 7992	373 4648
CORVETTE	69-79	All	452/453 & 454	MUNCIE & BW	391 7992	373 8611
CORVETTE	80-81	All	454	BW T-10	391 0028	373 8621
CORVETTE C4	89-96	V8		ZF6	391 5084 (4) Billet/Plus	(6)
CORVETTE C5	97-01	V8		BW T-56	391 5085 (4) Billet/Plus	(6)

(1) Black anodized round steel stick - uses stock factory boot. (*TT) - Torque Tube Tailhousing.

(3) See pages 53-55 for trans code information. (4) Supplied with black steel stick without knob, threaded for factory knob.

(5) Supplied with chrome-plated steel stick and black knob. (6) Internal Rail.

APPLICATIONS

COMPETITION/PLUS™



Model	Year	Description	Trans(3) Code	Transmission	Shifter Only	Installation Kit
CHEVROLET (CONTINUED)						
1/2 TON CHEVROLET & GMC PICKUPS	Custom installation		451	MUNCIE	391 0002	373 3163*
	when using		452/453	MUNCIE	391 0002	373 7834*
	passenger car		454	RICHMOND/BW T-10	391 0001	373 8609*
	transmissions		410	BW T-10	391 0002	373 4734*
			441	SAGINAW	391 0001	373 7919*
C-K SERIES TRUCKS	88-92	w/o Console	466	NEW VENTURE 3500	391 0120	(6)
1/2 ton, 3/4 ton	93-97	w/o Console	466	NEW VENTURE 3500	391 0121	(6)
	82-92	4-Cyl	464/465	BW T-4, T-5	391 0029 (4)	(6)
	82-94	w/o Console	464/465	BW T-4, T-5	391 0033 (5)	(6)
S SERIES TRUCKS	95-01	4-Cyl	466	NEW VENTURE 1500	391 0112	(6)
	91-94	6-Cyl	466	NEW VENTURE 3500	391 0110	(6)
	95-97	6-Cyl	466	NEW VENTURE 1500	391 0111	(6)
	98-01	6-Cyl	466	NEW VENTURE 3500	391 0113	(6)
NEW EL CAMINO	59	All	410	BW T-10	391 7307	373 3157
EL CAMINO	64-67	w & w/o Console	451	MUNCIE	391 7308	373 3163
EL CAMINO	66-67	w & w/o Console	441	SAGINAW	391 7307	373 4297
EL CAMINO	68	w & w/o Console	451	MUNCIE	391 8014	373 3163
EL CAMINO	68-72	w & w/o Console	441	SAGINAW	391 7930	373 7919
EL CAMINO	69-72	w & w/o Console	452/453	MUNCIE	391 8014	373 7834
EL CAMINO	74	w/Console	453	MUNCIE	391 6848	373 7897
EL CAMINO	78-80	w & w/o Console	441	SAGINAW	391 8794	373 0017
MONTE CARLO	70-72	w & w/o Console	452/453	MUNCIE	391 8014	373 7834
MONTE CARLO	78-80	w & w/o Console	441	SAGINAW	391 8794	373 0017
DODGE						
CHARGER	66-72	w/o Console	422	N. PROCESS	391 6789	373 4089
CORONET & SUPER BEE	65-72	w/o Console	422	N. PROCESS	391 6789	373 4089
NEW DAKOTA	94-00	V8	466	NV3500	391 0155 (5) Billet/Plus	(6)
DAKOTA*	94-99	V6		AX 15	391 5050 (5) Billet/Plus	(6)
DAKOTA*	90-96	I-4		AX 15	391 5050 (5) Billet/Plus	(6)
FORD						
FULL SIZE	62-64	w & w/o Console	411	BW T-10	391 6848	373 3166
FULL SIZE	64	w/Console	431	FORD T & C	391 6848	373 3167
FULL SIZE	64-65	w/o Console	431	FORD T & C	391 6848	373 3167
FAIRLANE & TORINO	64-65	w/o Console	431	FORD T & C	391 6848	373 3167
FAIRLANE & TORINO	66-69	w & w/o Console	433	FORD T & C	391 3180	373 7638
FAIRLANE & TORINO	70-71	w & w/o Console	433	FORD T & C	391 3180	373 7638
FAIRLANE & TORINO	72-73	w & w/o Console	433	FORD T & C	391 3180	373 5587
FALCON	66-67	8 Cyl. w & w/o Cons.	433	FORD T & C	391 3180	373 7638
FALCON	63-65	8 Cyl. w & w/o Cons.	412	BW T-10	391 8789	373 3164
MUSTANG	65-69	289, 302, 351 V-8 w & w/o Console	432	FORD T & C	391 3180	373 7637
MUSTANG	65-69	289, 302, 351 V-8 w & w/o Console	413	BW T-10	391 3180	373 3668
MUSTANG	67-69	390, 428, 429 V-8 w & w/o Console	433	FORD T & C	391 3180	373 5587
MUSTANG	70-73	302, 351 V-8 w & w/o Console	432	FORD T & C	391 3180	373 7637

*Modification to stick may be necessary to clear seat. A Hurst Super Boot is recommended for a professional looking installation. (Pt # 114 7494). (3) See pages 53-55 for trans code information. (4) Supplied with black steel stick. (5) Supplied with chrome-plated steel stick and black knob. (6) Internal Rail.



APPLICATIONS

COMPETITION/PLUS™

Model	Year	Description	Trans(3) Code	Transmission	Shifter Only	Installation Kit
FORD (CONTINUED)						
MUSTANG	83-93	w/Console	465	BW T-5	391 0030 (1)	(6)
MUSTANG	94-97	w/Console	465	BW-T-5	391 0131 (1)	(6)
MUSTANG	84-86	w/Console	465	BW T-5	391 0035 (2)	(6)
MUSTANG	83-86	w/Console	465	BW T-5	538 0035 (7) Stick Kit	-
MUSTANG	87-93	w/Console	465	BW T-5	391 0036 (2)	(6)
MUSTANG	87-92	w/Console	465	BW T-5	538 0036 (7) Stick Kit	-
MUSTANG	83-93	w/Console	469	TREMEC	391 0070 (1)	(6)
MUSTANG	83-93	V6/V8	465	BW T-5	391 5030 (4) Billet/Plus	(6)
MUSTANG	94-01	V6/V8	465	BW T-5 , T-45	391 5031 (4) Billet/Plus	(6)
MUSTANG	83-93		469	Tremec 3550	391 5070 (4) Billet/Plus	(6)
MUSTANG	83-98	V8		BW T56 (aftermarket)	391 5072 (4) Billet/Plus	(6)
NEW MUSTANG	2001	V8		Tremec 3650	391 5035 (4) Billet/Plus	(6)
THUNDERBIRD	83-91	w/Console	465	BW T-5	391 0031 (1)	(6)
THUNDERBIRD	83-91	V6/V8	465	BW T-5	391 5031 (4) Billet/Plus	(6)
RANCHERO	63-65	8 Cylinder w & w/o Console	412	BW T-10	391 8789	373 3164
RANCHERO	66-69	8 Cylinder w & w/o Console	433	FORD T & C	391 3180	373 7638
RANCHERO	70-71	w & w/o Console	433	FORD T & C	391 3180	373 7638
RANCHERO	72-73	w & w/o Console	433	FORD T & C	391 3180	373 5587
1/2 TON TRUCK	78-79	6 & 8 Cylinder Custom installation of passenger car transmission	3 + 1 431	FORD OD FORD T & C	391 0024 391 0001	373 8620* 373 3167*
NEW RANGER	88-00	V6		5 speed manual	391 5020 (5) Billet/Plus	(6)
NEW RANGER	88-00	4-CYL.		5 speed manual	391 5021 (5) Billet/Plus	(6)
NEW F-150	88-96	5.0L		5 speed manual	391 5025 (5) Billet/Plus	(6)
JEEP						
WRANGLER	90-98	I-6		AX-15	391 5040 (5) Billet/Plus	(6)
CJ-SERIES*	82-86	I-6		BW T4/T5	391 5045 (5) Billet/Plus	(6)
NEW CHEROKEE	89-99	I-6		AX-15	391 5042 (5) Billet/Plus	(6)
MERCURY						
FULL SIZE	61-64	w/Console	411	BW T-10	391 6848	373 3166
FULL SIZE	64	w/Console	431	FORD T & C	391 6848	373 3167
FULL SIZE	64-65	w/o Console	411	FORD T & C	391 6848	373 3167
COMET & CYCLONE	66-69 63-65	w & w/o Console w & w/o Console V8	433 412	FORD T & C BW T-10	391 3180 391 8789	373 7638 373 3164
COUGAR	67-68	289, 302 V-8 w & w/o Console	413	BW T-10	391 3180	373 3668
COUGAR	67-69	289, 302, 351 V-8 w & w/o Console	432	FORD T & C	391 3180	373 7637
COUGAR	67-69	390, 428, 429 V-8 w & w/o Console	433	FORD T & C	391 3180	373 5587
COUGAR	83-91	w/Console	465	BW T-5	391 0031 (1)	(6)
COUGAR	83-91	V6/V8	465	BW T-5	391 5031 (4) Billet/Plus	(6)
CAPRI	83-87	w/Console	465	BW T-5	391 0030 (1)	(6)
CAPRI	83-86	w/Console	465	BW T-5	391 0030 (1)	(6)

*Modification to stick may be necessary to clear seat. A Hurst Super Boot is recommended for a professional looking installation. (Pt # 114 7494)

(1) Black anodized round steel stick - uses stock factory boot. (2) Injected molded top plate, boot, chrome plated steel flat stick short throw, vibration insulators included. (3) See pages 53-55 for trans code information. (4) Supplied with black steel stick and without knob.

(5) Supplied with chrome-plated steel stick and black knob. (6) Internal Rail. (7) Stick Kit Only, does not include shifter. See page 17 for details.

APPLICATIONS

COMPETITION/PLUS™



Model	Year	Description	Trans(3) Code	Transmission	Shifter Only	Installation Kit
OLDSMOBILE						
F-85	64-65	w & w/o Console	451	MUNCIE	391 7308	373 3163
F-85	66	w/o Console	451	MUNCIE	391 7308	373 3163
442	64-65	w & w/o Console	451	MUNCIE	391 7308	373 3163
442	66	w/o Console	451	MUNCIE	391 7308	373 3163
442	78-79	w & w/o Console	441	SAGINAW	391 8794	373 0017
CUTLASS	78-79	w & w/o Console	441	SAGINAW	391 8794	373 0017
PLYMOUTH						
BELVEDERE & GTX	65-72	w/o Console	422	N. PROCESS	391 6789	373 4089
ROADRUNNER	68-72	w/o Console	422	N. PROCESS	391 6789	373 4089
PONTIAC						
FULL SIZE	60-64	w/o Console	410	BW T-10	391 7308	373 4734
FIREBIRD	67-68	w & w/o Console	441	SAGINAW	391 4339	373 4531
FIREBIRD	67-68	w & w/o Console	451	MUNCIE	391 4339	373 4529
FIREBIRD	69	w & w/o Console	452	MUNCIE	391 7438	373 7437
FIREBIRD	70-72	w & w/o Console	452/453	MUNCIE	391 6848	373 7897
FIREBIRD	74-81	w/o Console	454	BW T-10	391 8794	373 8609
FIREBIRD	74-81	w/Console	454	BW T-10	391 8791	373 8609
FIREBIRD	82	w/Console	455	BW T-10(TT)	391 7960	373 0021
FIREBIRD	82	w/Console	456	SAGINAW(TT)	391 7960	373 0022
FIREBIRD	83-92	V6/V8	464	BW T-5	391 5032 (1) Billet/Plus	(6)
FIREBIRD	93-01	V6	464	BW T-5	391 5032 (1) Billet/Plus	(6)
FIREBIRD	93-01	V8	468	BW T-56	391 5060 (4) Billet/Plus	(6)
FIREBIRD	93-01	V8	468	BW T-56	391 5061 (5) Billet/Plus	(6)
GRAND PRIX	78-79	w & w/o Console	441	SAGINAW	391 8794	373 0017
G.T.O	64-66	w/o Console	451	MUNCIE	391 7308	373 3163
TEMPEST & LEMANS	64-66	w/o Console	451	MUNCIE	391 7308	373 3163
TEMPEST & LEMANS	66	w/o Console	441	SAGINAW	391 4339	373 4531
TEMPEST & LEMANS	78-79	w & w/o Console	441	SAGINAW	391 8794	373 0017
VENTURA II	71-73	w/o Console	453	MUNCIE	391 6848	373 7834
SHELBY MUSTANG						
GT-350	65-69	w & w/o Console	413	BW T-10	391 3180	373 3668
GT-500	67-69	w & w/o Console	433	FORD T & C	391 3180	373 5587
STUDEBAKER						
HAWK	59-64	w/Bucket Seats	410	BW T-10	391 7308	373 4734

COMP STICK FOR MUSTANG T-5 TRANSMISSION

Hurst now has available a competition stick kit for the 1983-92 Ford Mustang equipped with a Borg-Warner T-5 manual transmission. The Comp Stick Kit fits the stock OEM shifter mechanism and aftermarket Hurst Competition Plus shifter mechanism. Each kit consists of a white shift knob with gear shift pattern, chrome-plated flat shifter stick, rubber vibration isolater, shifter boot, and console top plate with the famous Hurst shifter logo.

Year	Description	Comp. Stick Kit
1983-86	Mustang w/factory Console & T-5 Trans	538 0035
1987-92	Mustang w/factory Console & T-5 Trans	538 0036



- (1) Black anodized round steel stick - uses stock factory boot.
- (TT) - Torque Tube Tailhousing. (3) See pages 53-55 for trans code information.
- (4) Supplied with black steel stick and without knob.
- (5) Supplied with chrome-plated steel stick and black knob.
- (6) Internal Rail.



TRUCK SHIFTERS

COMPETITION/PLUS™ & BILLET/PLUS™

The traditional Hurst Competition/Plus Shifter is now available for many later model pick-up trucks equipped with manual transmissions. This shifter is designed to provide a more positive and secure feel when shifting and incorporates a high ratio pivot mechanism for approximately 30% reduced knob travel resulting in shorter, quicker shifts. Patented adjustable bias spring loads allow stick tension to be tailored for driver's preference, and positive gear stops prevent overshifting and internal transmission damage. Supplied with chrome plated bolt-on stick with black knob and is easily installed without any vehicle modifications. U.S. Patent No. 4,581,951.

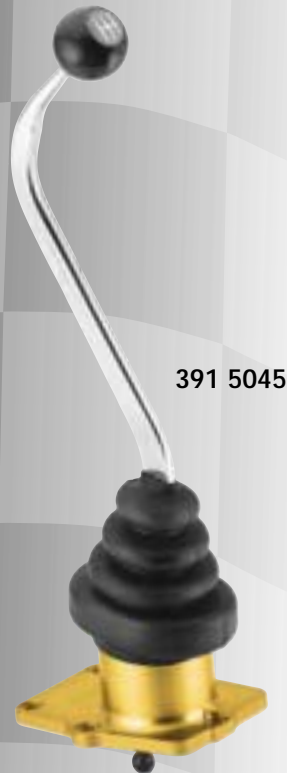

391 5045



#391 0112



391 0155



391 0110

APPLICATIONS

COMPETITION/PLUS

Make	Model	Year	Engine	Transmission	Trans. Code	Shifter
Chevy/GMC	CK-Series 1/2 & 3/4 Ton	88-93	V6/V8	New Venture MG-5 3500	466	391 0120
Chevy/GMC	CK-Series 1/2 & 3/4 Ton	94-97	V6/V8	New Venture MG-5 3500	466	391 0121
Chevy/GMC	S10/S15 Series	82-94	4-Cyl	Borg-Warner T4, T5	464	391 0029 (4) 391 0033
Chevy/GMC	S10/S15 Series	95-01	4-Cyl	New Venture 1500	466	391 0112
Chevy/GMC	S10/S15 Series	91-94	V6	New Venture 3500	466	391 0110
Chevy/GMC	S10/S15 Series	95-97	V6	New Venture 3500	466	391 0111
Chevy/GMC	S10/S15 Series	98-01	V6	New Venture 3500	466	391 0113
NEW Dodge	Dakota	94-00	V8	NV3500	466	391 0155

BILLET/PLUS

Make	Model	Year	Engine	Transmission	Trans. Code	Part No.
Dodge	Dakota	94-99	V6	AX 15		391 5050
Dodge	Dakota	90-96	I-4	AX 15		391 5050
Jeep	Wrangler	90-98	I-6	AX-15		391 5040
Jeep	CJ-Series	82-86	I-6	BW T4/T5		391 5045
Jeep	Cherokee	89-99	I-6	AX-15		391 5042
Ford	Ranger	88-00	V6	5 speed manual		391 5020
Ford	Ranger	88-00	4-CYL	5 speed manual		391 5021
Ford	F-150	88-96	5.0L	5 speed manual		391 5025

CUSTOM GM TRUCK APPLICATIONS 4-SPEED SHIFTERS

Model	Description	Trans. Code	Transmission	Shifter	Installation Kit
1/2 Ton Chevrolet & GMC Pick-ups	Custom installation	451	Muncie	391 0002	373 3163
	when using passenger car transmissions.	452	Muncie	391 0002	373 7834
		453	Muncie	391 0002	373 7834
		410	Borg-Warner	391 0002	373 4734
	Modification to stick may be necessary to clear seat.	441	Saginaw	391 0001	373 7919
		454	Richmond/BW Super T-10	391 0002	373 8609

NOTE: Will not fit vehicles with body lift kit. (3) See pages 53-55 for trans code information.

(4) Supplied with black aluminum stick and black knob. See Mastershift Applications for 3-speed shifters, page 14-17

STREET SUPER/SHIFTER™

4-SPEED



Based on the racing version of the legendary Super Shifter 3, the Hurst Street Super/Shifter brings many of the same quality features to a new level of performance.

- Utilizes a 7-1/2" tall chrome-plated stick (3/8-16 thread) for a short throw, 4-3/4" knob travel between gears.
- High mounting design assures proper linkage rod alignment.
- Heat treated components for extra strength and reliability.
- Adjustable gear stops to prevent overshifts.
- Complete with all necessary hardware and easy to follow installation guide.
- Shifter assembly and installation kit each sold separately.

Optional Hurst Super Boot #114 7494 recommended for finished appearance and sold separately.

NOTE: Street Super/Shifters are not vehicle specific. They will fit transmission, but will not fit stock consoles and often require minor floor pan modification for installation.



#391 7535 Shifter
#373 8616 Installation Kit

A P P L I C A T I O N S

STREET SUPER SHIFTER

Transmission	Trans. Code	Shifter Only	Installation Kit
MUNCIE	451	391 7535	373 8616
MUNCIE	452, 453	391 7535	373 8616
BW T-10	410	391 7535	373 8616
RICHMOND/BW SUPER T-10	454	391 7535	373 8616
SAGINAW	441	391 7535	373 8618
NEW PROCESS	421	391 7535	373 8617
FORD T & C	432-433	391 7535	373 8615

See pages 47-49 for custom stick selection.



MANUAL SHIFTERS

MASTERSHIFT™ 3-SPEED

Hurst's Mastershift 3-speed shifter is designed to provide precise gear selection and dependable long life. Popular as both a replacement floor shift and a column shift conversion.



#366 7271

- Exclusive advanced gear shift mechanism design for shorter throw and positive, precise shifts
- Heat treated components for durability and longer life
- Attractive chrome-plated steel stick with 3/8-16 thread and custom white knob
- Installation kits include all linkage, mounting hardware, shifter boot and easy-to-follow installation guide
- Shifter assembly and installation kit are each sold separately



#366 6809 Shifter

#367 0006 Installation Kit



MANUAL SHIFTERS

MASTERSHIFT™ APPLICATIONS



Model	Year	Description	Trans. Code	Trans.	Shifter Only	Installation Kit
BUICK						
GRAN SPORT & SPECIAL	66-67	6 & 8 Cylinder w/o Console	343	SAGINAW	366 7271	367 0010
CHEVROLET						
FULL SIZE	55-57	All	341	CHEVROLET	366 6901	367 3111
FULL SIZE	58-64	6 & 8 Cylinder w/o Console	341	CHEVROLET	366 7271	367 3111
FULL SIZE	66-70	6 & 8 Cylinder w/o Console	343	SAGINAW	366 6901	367 7143
CHEVELLE	66-72	6 & 8 Cylinder w/o Console	343	SAGINAW	366 7271	367 0010
CHEVELLE	73-74	6 & 8 Cylinder w/o Console	343	SAGINAW	366 7271	367 0010
EL CAMINO	59-60	6 & 8 Cylinder w/o Console	341	CHEVROLET	366 7271	367 3111
EL CAMINO	66-72	6 & 8 Cylinder w/o Console	343	SAGINAW	366 7271	367 7143
EL CAMINO	73-74	6 & 8 Cylinder w/o Console	343	SAGINAW	366 7271	367 0010
PICK-UP	55-66	All 1/2 Ton	341	CHEVROLET	366 6809	367 3112
PICK-UP	67-68	6 Cylinder Only 1/2 Ton	341	CHEVROLET	366 6809	367 3111
PICK-UP	67-68	8 Cylinder Only 1/2 Ton	343	SAGINAW	366 6809	367 7143
PICK-UP	69	6 & 8 Cylinder 1/2 Ton	343	SAGINAW	366 6809	367 7143
PICK-UP	69-87	All 1/2 & 3/4 Ton 2 Wheel Drive	343/351	SAGINAW/ MUNCIE	366 6809	367 0006
PICK-UP	69-77	also Blazer & Suburban*	343/351	MUNCIE	366 6809	367 0006
PICK-UP	69-77	All 4 Wheel Drive	343	SAGINAW	366 6901	367 0025
VAN	71-87	All 2 Wheel Drive	343/351 352	SAGINAW/ MUNCIE TREMEC	366 0014	367 0023
FORD						
BRONCO	66-77	8 Cylinder - only	333	FORD T & C	366 6901	367 0013
MUSTANG	65-73	289, 302, 351 V-8 & w/o Console	336	FORD T & C	366 3179	367 7640
MUSTANG	65-73	6 Cylinder w & w/o Console	336/337	FORD	366 3179	367 7640
VAN	75-79	All	333/339	FORD T & C	366 6809	367 0014
PICK-UP 1/2 TON	63-87	All 2 Wheel Drive*	333	FORD	366 6809	367 0027
RANCHERO	63-65	8 Cylinder w & w/o Console	333	FORD T & C	366 6901	367 3122
GMC						
VAN	71-81	6 & 8 Cylinder	343/351 352	SAGINAW, MUNCIE TREMEC	366 0014	367 0023
1/2 & 3/4 TON PICK-UP	68-81	All 2 Wheel Drive*	343	SAGINAW	366 6809	367 0006
	68-77	All 2 Wheel Drive*	351	MUNCIE	366 6809	367 0006
MERCURY						
COUGAR	67-69	289, 302, 351 V-8 w & w/o Console	336	FORD T & C	366 3179	367 7640
METEOR	63	8 Cylinder w/o Console	333	FORD T & C	366 3179	367 7640
OLDSMOBILE						
CUTLASS F-85 & 442	66-72	6 & 8 Cylinder w/o Console	343	SAGINAW	366 7271	367 0010
PONTIAC						
FULL SIZE	58-63	w/o Console	341	CHEVROLET	366 6901	367 3111
G.T.O. & TEMPEST	66-73	w & w/o Console	343	SAGINAW	366 7271	367 0010

*Modification to catalytic converter bracket may be necessary if vehicle is so equipped.
See pages 47-49 for custom stick selection.
See page 52 for trans code information.



MANUAL SHIFTERS

QUICK/STICK™

Hurst Quick/Stick shifters are designed exclusively for sport compact cars with manual transmissions. They put the fun back into shifting by reducing shift lever throw by 30% and by using better materials machined to closer tolerances to provide a more positive and precise shift.



- All Quick/Stick Shifters are CNC machined from billet steel and/or billet aluminum for extra strength
- Engineered as a direct bolt-in replacement shifter for a simple, easy installation
- Sticks accept the stock factory knob or most aftermarket custom shift knobs, in addition to the popular Hurst T-Handle



APPLICATIONS

HURST QUICK/STICK

Model & Year	Color	Part No.
Civic/CRX 1988-97, Acura Integra 1990-97	Black	391 4000
	Silver	391 4002
	Blue	391 4004
	Red	391 4006
	Purple	391 4008
Model	Year	Part No.
Dodge Neon	1994-2001	391 4015
Mitsubishi Eclipse	1995-1998	391 4025
Eagle Talon	1995-1997	391 4025
Chrysler Sebring	1995-1996	391 4025
Dodge Avenger	1995-1996	391 4025
Chrysler PT Cruiser	2001	391 4030



URETHANE SHIFTER STABILIZER KIT

This kit replaces the soft factory rubber shifter rod mount and bushing, providing a more positive feel of the shifter to help eliminate missed shifts under competition. A must when using the Hurst Quick/Stick Shifter or other aftermarket performance shifters. Easily installed.

Year/Model	Part No.
1990-97 Acura Integra	332 1000
1988-97 Honda Civic/CRX	332 1002
1984-87 Honda Civic/CRX	332 1000

INDY SHIFTERS

UNIVERSAL 4-SPEED



Hurst/Indy 4-Speed Shifter Kits are designed to be used on most popular 4-speed transmissions and a wide variety of cars. Applications are determined by transmissions and an exclusive engineered mounting design, making them adaptable to many popular passenger car floor pans.

- Adaptable to most popular passenger cars
- Narrow spring-loaded gate for ease of operation
- Heat-treated and plated parts for added strength and durability
- 7-1/2" tall chrome-plated stick (3/8-16 thread) provides short, precise throws
- Comes complete with all hardware, linkage and easy-to-follow instruction guide

NOTE: The high mounting location of these kits often eliminates their use with factory consoles. Trim modifications to floor pans is often necessary.



Shown with optional Hurst Boot #114 8429 (recommended for a professional appearance)

APPLICATIONS

PART NO. 503 0030

- Transmission used as original equipment on pre-69 GM cars
- 7-bolt side cover
- Reverse shaft in extension housing
- Forward gear shifting shafts straight when trans in neutral
- Arms attach with stud and nut

PART NO. 503 0030

- Transmission used as original equipment in '69 and later cars
- 7-bolt side cover
- Reverse shaft in extension housing
- Forward gear shifting shafts straight when trans in neutral
- Arms attach with bolt

PART NO. 503 0030

- Transmission used as original equipment in '74 and later GM cars
- 9-bolt curved bottom side cover
- Reverse shaft in extension housing
- Forward gear shifting shafts straight when trans in neutral
- Arms attach with stud and nut

PART NO. 503 0030

- Standard T-10 used as original equipment in '58-'63 GM cars
- Super T-10 is an aftermarket replacement unit
- 9-bolt side cover
- Shifting shafts are on an angle when trans is in neutral

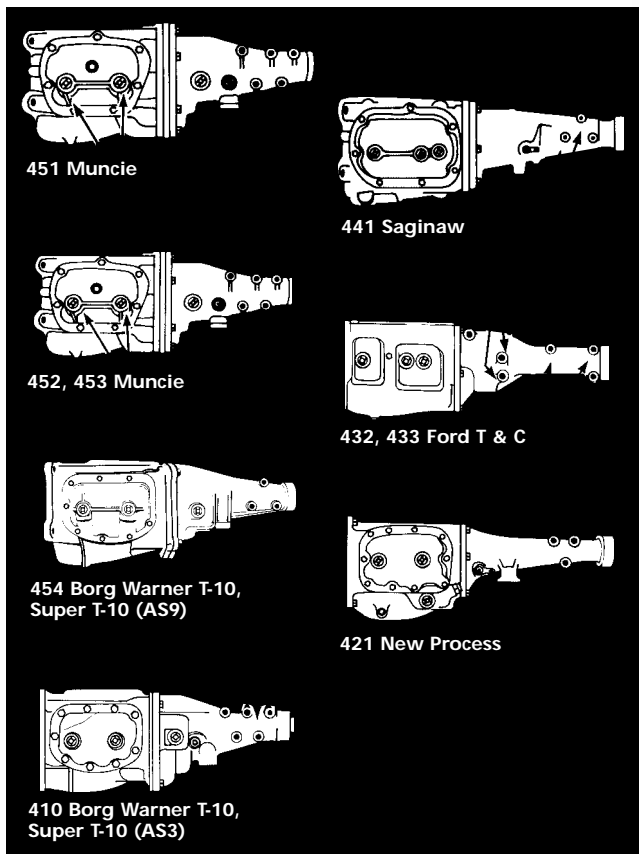

PART NO. 503 0033

- Transmission used as original equipment in GM cars
- All shifting shafts located on side cover
- 7-bolt side cover
- Arms attach with bolt

PART NO. 503 0031

- Transmission used as original equipment in '62 and later Ford Motor Corp. cars
- 10-bolt top cover
- All shifting shafts on side of main case
- Extension housing may have more than one shift mounting location

PART NO. 503 0032

- Transmission used in '66 and later small Chrysler Corp. cars (Demon, Duster, etc.)
- Reverse shaft in lower portion of main case
- 10-bolt side cover



INDY SHIFTERS

INDY MATIC 1

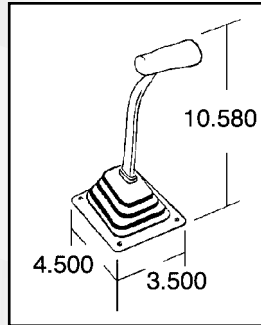

#506 0001

- Fits many popular 2 and 3-speed automatic transmissions
- Universal floor mount for easy installation, ideal for column shifter conversion
- Safety detented for precise shifting control
- Linkage rod activated
- All parts are plated for lasting protection
- Attractive chrome-plated stick with black T-handle for comfort shifting
- Complete with shifter boot, hardware and easy to follow installation guide
- Must use factory neutral safety switch



INDY MATIC 1

Make	Year
Chevrolet Powerglide	51-73
Buick TH 350 & 400, Chevrolet TH 350 & 400,	65-81
Oldsmobile TH 350 & 400 (except Toronado), Pontiac TH 350 & 400	65-81
Oldsmobile Turbo-Hydramatic, Pontiac Turbo-Hydramatic	49-60
Chrysler Torqueflite 727 & 904 (Dodge, Plymouth & Chrysler)	64-81
Ford & Mercury Cruise-o-matic DR, Ford & Mercury Ford-o-matic DR	58-81
Ford-o-matic SR	57-59

INDY PICK UP TRUCK 3-SPEED SHIFTER

This popular Indy shifter is available for pick-up trucks and is a perfect replacement for old floor shifters, or an ideal column shift conversion.

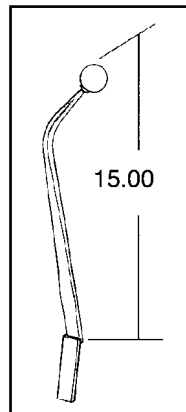

#501 0016

- Extended chrome-plated stick (uses 3/8-24 thread) to accommodate pick-up truck seat height
- Precise selector pin mechanism
- Spring loaded gate for positive shifts
- All parts plated for protection
- Stamped with Hurst/Indy identification
- Complete with all linkage, mounting hardware, and easy to follow installation guide
- Shown with optional Indy Boot & Plate #114 8429 recommended for finished appearance



INDY PICK-UP TRUCK

Make	Year
GENERAL MOTORS All two-wheel drive with Saginaw, Muncie & Tremec transmissions	69 & Later
FORD MOTOR CO. All two-wheel drive with Ford & Tremec transmissions	63 & Later

INDY 3-SPEED SHIFTERS



INDY QUALIFIER

- Economically priced
- Universal design - one part number fits most applications
- Ideal for column shift conversion
- Chrome-plated stick with black plastic knob
- All components plated for protection
- Complete with hardware and easy-to-follow installation guide
- Shown with optional Boot & Plate #114 7336

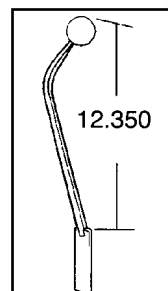

#501 0018



INDY QUALIFER #501 0018	
Make	Year
GM	
Buick*	64-Later
Chevrolet-Standard & H.D. 6 & 8 cylinder	55-Later
Chevelle, Camaro, Chevy II	62-Later
Oldsmobile-Standard & Intermediates*	49-Later
Pontiac-Standard & H.D.*	58-Later
Pontiac Firebird, Tempest & LeMans	64-Later
CHRYSLER	
Chrysler, Plymouth, DeSoto, Dodge, except A body Chryslers (Demon, Dart, Duster)	57-Later
FORD	
Ford-standard & H.D. 6 & 8 cylinder	49-Later
Falcon, Fairlane, Torino - 6 & 8 cylinder	62-Later
Lincoln	49-Later
Mercury-standard & H.D. 6 & 8 cylinder	49-Later
Meteor, Comet, Cougar - 6 & 8 cylinder	49-Later
PICK-UP TRUCKS	
3-spd. transmission standard & H.D. Ford, Chevrolet, GMC, Dodge (except '71 and later Dodge pick-up trucks).	55-Later

#501 0002

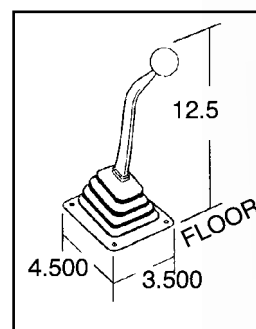

INDY SSA

- Spring loaded gate for ease of operation
- Short precise throws for less stick travel
- Attractive chrome-plated stick (3/8-24 thread) can be adjusted to different positions
- Ideal for floor shift replacement or column shift conversion
- Fits most popular passenger cars with 3-speed manual transmissions
- All components are plated for protection
- Complete with shifter boot, hardware and easy-to-follow installation guide

INDY SSA UNIVERSAL #501 0002	
Make	Year
GM	
Buick*	64-Later
Chevrolet-Standard & H.D. 6 & 8 cylinder	55-Later
Chevelle, Camaro, Chevy II	62-Later
Oldsmobile-Standard & Intermediates*	49-Later
Pontiac-Standard & H.D.*	58-Later
Pontiac Firebird, Tempest & LeMans	64-Later
CHRYSLER	
Chrysler, Plymouth, Dodge Standard & Intermediate (except Duster, Demon, Challenger)	57-Later
FORD	
Ford & Mercury Standard	49-Later
Fairlane, Montego, Torino, Meteor, Falcon, Comet	62-Later

* Note: Will fit all 6 cyl., HD and standard 3-speed transmissions except selector type gear boxes (single shaft). Certain applications require a great deal of modification to make shifter fit.



DRAG RACING SHIFTERS

V-GATE 2™ IN-LINE SHIFTER

This original vertical gate in-line competition shifter is the most dependable 4 and 5 speed manual transmission shifter for drag racing. Drivers can maintain positive gear control and run consistently with simple straight push/pull movements.



411 8156-shifter
373 8190-kit

- Built-in stops prevent overshifting and heavy-duty springs provide added performance dependability
- Internal mechanisms are heat treated for added strength and durability
- First gear incorporates a built-in lock out for added safety
- Separate lever for positive reverse Loc/Out
- Complete with Hurst aluminum T-Handle (3/8-16 thread) and easy to follow installation guide
- Installation kit and V-Gate 2 Boot #114 1653 sold separately

SHIFT PATTERNS

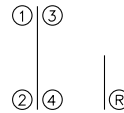

4-SPEED V-GATE 2 SHIFT PATTERN

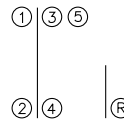

5-SPEED V-GATE 2 SHIFT PATTERN

APPLICATIONS

V-GATE 2

Make	Year	Transmission	Trans. Code	Shifter Only	Installation Kit
GM	74 & LATER	Richmond/BW T-10, 2nd design AS-9 Series	454	411 8156	373 8165
	ALL	BW T-10, 1st Design	410	411 8156	373 8190
	63-68	Muncie Arms Attached w/Stud & Nut	451	411 8156	373 8190
	69 & LATER	Muncie Arms Attached w/Bolt	452	411 8156	373 8190
	ALL	Saginaw 3 bolt Mounting Position in Extension Housing	441	411 8156	373 8164
FORD	65-75	BW T-10, Super T-10	415	411 8156	373 8174
	65-75	T & C Rear Location	432	411 8156	373 8172
	67-69	T & C	433	411 8156	373 8171
	70-75	T & C	434	411 8156	373 8175
MOPAR	-	New Process B-Body	422	411 8156	373 8182
	-	New Process A-Body	421	411 8156	373 8180
RICHMOND	-	Richmond/Doug Nash/G-Force 5-Speed	467	411 8157	373 8188
	-	Richmond/BW-T10 4-Speed	454	411 8156	373 8165
JERICO	-	Jerico 4-Speed	-	411 8156	373 8193

NOTE: Floor and console must be modified for shifter installation.

RECOMMENDED FOR USE WITH: Bucket seats or modified bench seat.

See service part section for component information. See pages 53-55 for trans code information.

DRAG RACING SHIFTERS

SUPER/SHIFTER 3



One of the most legendary Hurst Shifters ever engineered! Considering its impressive list of features, the Super Shifter 3 supports Hurst's well-earned reputation as "America's Number One Shifter."

- Incorporates a positive reverse Loc/Out mechanism that provides the most secure method of blocking the reverse gate ever offered
- Heat treated trans arms and internal mechanism components assure strength and durability
- Reinforced heat treated linkage rods eliminate flex
- Shifter rods and adjustable rod buttons are secured with special locking jam nut to provide more positive attachment and alignment
- Complete with hardware and easy to follow installation guide
- Chrome-plated stick has 3/8-16 thread
- Shifter and installation kit each sold separately

Optional Hurst shifter boot #114 0010 recommended for finished appearance



491 0001

A P P L I C A T I O N S

SUPER SHIFTER 3

Transmission	Trans. Code	Shifter Only	Installation Kit
MUNCIE	451	491 0001	373 0006
BW T-10	454	491 0001	373 0006
MUNCIE	452, 453	491 0001	373 0007
NEW PROCESS	422, 423	491 0001	373 0011
FORD T & C	432, 433	491 0001	373 0014

See pages 47-49 for custom stick selection.

See pages 53-55 for trans code information.



DRAG RACING SHIFTERS

RICHMOND 5-SPEED

Hurst offers state of the art shifter control for Richmond Street or Race 5-speed transmissions. These shifters offer the highest quality materials, workmanship and design in the industry today.

- Shifter mounts low and close to the transmission case for ease of installation in most applications
- Incorporates a neutral bias shift pattern that centers the stick to the 3-4 gate in neutral, requiring a bias effort to overcome the preload spring to enter the 1-2 or 5-R gate
- Built-in gear stops prevent overshifting
- Internal mechanism components are heat treated for strength and durability
- Reinforced heat treated 7/16" linkage rods eliminate flex
- Complete with installation kit and easy to follow installation guide
- Chrome-plated stick has 3/8-16 thread

NOTE: This shifter will also work with the earlier version transmission known as the Doug Nash 5-speed and the G-Force transmission.



407 0009

SHIFT PATTERN

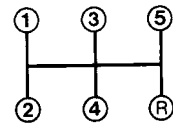

APPLICATIONS

RICHMOND 5-SPEED

Transmission	Trans. Code	Shifter & Installation Kit
Richmond Street & Race 5-Speed	467	407 0009
Richmond Street & Race 5-Speed	467	407 0015(1)

(1) Supplied with 7-1/2" stick #538 7238 See pages 47-49 for custom stick selection. See pages 55 for trans code information.

DRAG RACING SHIFTERS

PRO V-GATE



The Pro V-Gate 5 shifter is the winning choice for Pro-Stock, Comp Eliminator and Mustang Shootout classes.

This shifter features a one piece billet aluminum handle for superior strength, and provides a comfortable natural feel when shifting, allowing less chance of your hand slipping off a ball. The unique pistol grip handle provides a much more secure grip for precise, positive shifts. The gate trigger is designed and positioned to be quickly and easily pulled back with the same hand used for shifting, allowing quick engagement into 1st gear. A built-in Roll/Control switch is conveniently located on top of the handle.

- Dual pivot action for optimum operation — all shifts actuate linkage in a compression (forward) action
- Precision machined 4130 Chrome Moly shift levers and trans arms assure added strength to prevent breakage
- Lightweight design incorporates aluminum side plates and 4130 Chrome Moly seamless tubular shift rods featuring RH and LH threaded rod ends for easy adjustment without disconnecting linkage
- Neutral gear stops eliminate transmission slider and shift fork drag
- High quality precision "snap action" switches (1 at each gear position) are used for controlling ignition retard, shocks, etc. Complete with wiring harness and weather proof connectors.
- Includes lightweight aircraft fasteners and self locking nuts

**Available for Liberty Equalizer
5 speed transmission only from
Hurst Specialty Shifter Division
Call 216-688-8300 ext. 439**





DRAG RACING SHIFTERS

LIGHTNING RODS™ FOR LENCO'S

Pro-Mod, Pro-Stockers and drag racers alike require lightning-quick, accurate shifts. That's why more champions choose to stay with the best — Lightning Rods for Lenco's by Hurst. Available for 4 or 5 speed Lenco transmissions.

- Exclusive Hurst round-to-flat anodized aluminum sticks.
- Quick release mounting pin system.
- Adjustable threaded ball rod end linkage.
- Exclusive F/N/R positive detent gate with chrome-plated squeeze handle.
- Multiple mounting locations.



#384 0013



#384 0022

A P P L I C A T I O N S

4-SPEED

Mounting Positions

Forward

Intermediate

Rear

Shifter & Installation Kit

384 0006 Straight Handles

384 0016 Bent Handles

384 0002 Straight Handles

384 0012 Bent Handles

384 0003 Straight Handles

384 0013 Bent Handles

5-SPEED

Intermediate

Rear

384 0022

384 0023

SPECIALTY SHIFTERS

SPEEDWAY SUPER/SHIFTER™



Hurst's Speedway Super/Shifters are used in professional circle track racing such as NASCAR, Winston Cup and Busch Grand National Series. The Speedway Super/Shifter utilizes weight-saving materials, space-age coatings and provides the ultimate in manual transmission control for endurance and competition.

- Advanced linkage system for proper shifting geometry and space-age coating to reduce drag and decrease wear
- Low mounting proximity helps eliminate tail housing flex
- Heavy-duty internal mechanism components are heat treated for strength and durability to provide additional performance and dependability
- Lubrication management system for ease of maintenance between races
- All grade 8 hardware comes predrilled for safety wire
- Shifter can be tailored to specific driver locations by utilizing the extensive line of bolt-on steel or aluminum sticks
- Installation kit sold separately

Shown with optional shifter stick and knob.

See pages 47-49 for custom stick selection.

See pages 55 for trans code information.

#491 0004



A P P L I C A T I O N S

SPEEDWAY SUPER/SHIFTER

Transmission	Trans. Code	Shifter Only	Installation Kit
Richmond/BW Super T-10	454	491 0004	373 0024
Muncie	453	491 0004	373 0025

BLUEPRINTED SUPER/SPEEDWAY SHIFTER

This shifter is used by many of the specialty transmission manufacturers who supply the leading 'cup' teams.

- Selector levers are blanchard ground to assure smooth operation
- CNC machined selector pin is assembled with solid bias pins for precise gear changes
- Heat-treated selector pin and levers insure reliability and long life
- Electro-nickel plated to resist corrosion
- Push down reverse lock-out prevents accidental engagement
- Supplied with additional shim plates, special carriage pivot bolt, roll pins and spring washers for serviceability

Part No. 491 0010

Shifter stick and linkage is not included. See pages 47-49 for custom stick selection.





THE ORIGINAL ROLL/CONTROL®

Used primarily in drag racing to provide positive locking action to the front wheels of race cars, reducing the chance of "Rolling the Lights" and producing more effective "Burn Outs" for heating up the tires. Rigorous testing has proved a 1/100,000 of a second release time and vibration tests have seen up to 30 G's applied without mechanical failure. Adaptable to most domestic and import hydraulic brake systems.

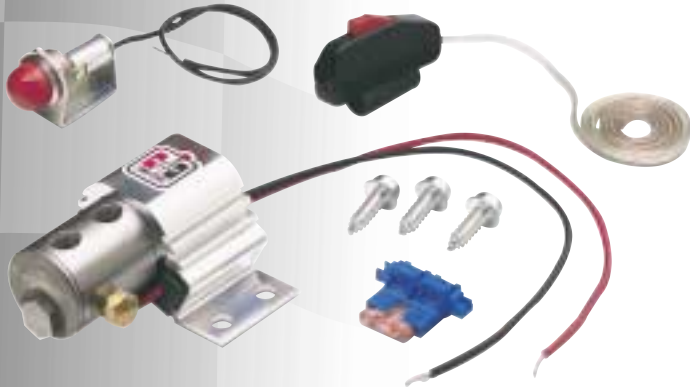

- Advanced quality design stainless steel valve assembly for ultimate corrosion resistance
- Fully enclosed epoxy molded electrical coil for reliability
- Attractive finned aluminum housing helps dissipate heat
- Wider lightweight base provides better mounting stability
- Field serviceable for cleaning or rebuilding
- Threaded port for separate bleeder or brake line pressure gauge
- Kit includes solenoid valve, snap-action switch, indicator light, fuse, mounting screws and installation instructions

* 12-volt negative ground systems only.

Part No. 174 5000

CAUTION: The Hurst Roll/Control or Line Loc® should not be used as an emergency brake, or any application requiring the solenoid to be activated for a long period of time.

ROLL/CONTROL ACCESSORIES



ROLL/CONTROL ADAPTER FITTING KITS

These adapter fitting kits simplify the installation of a Roll/Control or Line/Loc system into late model Camaro, Firebird or Mustang vehicles having metric threaded brake line fittings. Designed to be used with the Hurst Roll/Control Installation Kit #567 1510, these new kits consists of special conversion fittings needed for a fast, simple installation.

Make/Model	Year	Part No.
Chevrolet Camaro/Pontiac Firebird	93-00	567 1515
Chevrolet Corvette	85-96	567 1515
Ford Mustang	83-00	567 1516



ROLL/CONTROL INSTALLATION KIT

The Roll/Control Installation Kit is designed to be used in conjunction with most brake holding devices on American made vehicles. This kit contains brake lines and various brass fittings, connectors, adapters, unions and plugs necessary for an easy installation. Part No. 567 1510

ROLL/CONTROL REPLACEMENT PARTS

Description	Part No.
Roll/Control Rebuild Kit	567 1500
Solenoid only	566 7550
Replacement Switch	248 3875

ROLL/CONTROL ACCESSORIES



COMPETITION SHIFTER KNOB WITH BUILT-IN 12-VOLT SWITCH

Ideal for use with Hurst Roll/Control, trans brake, nitrous oxide systems or other 12 volt accessories. Available in black only.

Thread Size	Part No.
3/8 x 16"	163 0049
7/16 x 20"	163 0050



T-HANDLE WITH BUILT-IN 12-VOLT SWITCH

The ideal command switch for use with Hurst Roll/Control, trans brakes, nitrous oxide systems or other 12 volt accessories, 10-amp capacity, normally open. Now with new snap action button switch for instant activation. Available in brushed aluminum finish only.

Thread Size	Part No.
3/8-16	153 0003
3/8-24	153 0006
7/16-20	153 8510
Mustang 12mm x 1.75	153 4910
Camaro/Firebird 16mm x 1.50	153 4960



ROLL/CONTROL SWITCH

The Roll/Control Switch incorporates a micro switch for an immediate and accurate release. Includes 2 feet of wire for installation hookup to the Roll/Control, nitrous systems, trans brakes or other 12 volt accessories. 10 amp capacity. Normally open.

Description	Part No.
Replacement Switch for Hurst Roll/Control	248 3875



SPIRAL CORD WITH HIGH-SPEED SNAP ACTION SWITCH

This precision snap-action switch is ideal for operating Roll/Controls, nitrous systems, trans brakes, etc. The switch is designed to provide instantaneous, smooth operation under the most severe racing conditions.

- Low contact resistance for instantaneous response
- High shock resistance
- Moisture and dust proof for marine and off-road racing
- Epoxy sealed contacts and terminals
- 6' (18 gauge) coil cord for mounting in almost any location
- 10 amp. capacity
- Normally open

Part No. 248 3880

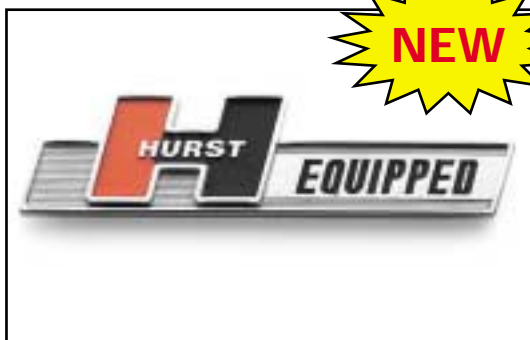

HURST EQUIPPED EMBLEM

Based on original HURST blueprints, this HURST EQUIPPED emblem is an authentic reproduction of the one used on the late '60's muscle cars equipped with a factory Hurst shifter. Made of durable ABS plastic with 3M adhesive tape backing for permanent mounting. Nominal size is 1-1/4" high by 5 -1/4" long. Individually packaged.

Part No. 136 1000

SEE PAGE 46 FOR SHIFTER CABLES AND PIT PACK BUSHING KITS



SHIFTER KNOBS & T-HANDLES



CLASSIC SHIFTER KNOBS

- Original Hurst Classic design
- Solid high gloss, high strength plastic
- Engraved inlaid shift pattern
- 1-3/4" diameter, exc as noted below
- Molded-in brass thread insert
- Complete with jam nut



THREAD SIZE	4 SPEED		5 SPEED		6 SPEED	
	White	Black	White	Black	White	Black
3/8-16	163 0003	163 0103	163 0008	163 0108	--	163 0140
3/8-24	163 0002	163 0102	--	--	--	--
7/16-20	163 0022	--	163 0004	163 0104	--	--
12mm x 1.75	--	--	*163 0014	*163 0114	--	--
16mm x 1.50	--	--	--	--	*163 0016	*163 0116

* 2.25" Diameter



REPLACEMENT SHIFTER KNOBS

- Solid high gloss plastic knob with clear plastic lens cover and logo
- Molded-in metal thread insert, complete with jam nut

THREAD SIZE	3 SPEED	4 SPEED	5 SPEED	4 & 5 SPEED	QUARTER STICK		INDY
	White	White	White	Black	White	Black	Black
3/8-16	163 7624	163 7626	163 0025	--	--	--	163 7200
3/8-24	--	163 3627	--	--	--	--	--
7/16-20	--	163 0061	163 0061	163 0062	163 1036	163 1037	--

UNIVERSAL SHIFTER KNOBS

- Solid high gloss plastic knob with aluminum threaded insert
- Clear top lens design permits use of a photo or vehicle name on the knob
- Includes over 30 vehicle names and shift patterns
- Fits 5/16-18, 7/16-20, 3/8-16, 3/8-24, 1/2-20 and 9/16-18 threaded shift levers

COLOR	PART NO.
White	163 0037
Black	163 0038



COMPETITION KNOBS & T-HANDLES WITH SWITCH

- Features a heavy-duty, quick release 12 volt normally open switch w/24" long wire lead
- Ideal for use w/Roll/Control, trans brake, nitrous, etc
- Solid plastic knob w/jam nut
- Quality die cast aluminum T-handles

THREAD SIZE	BLACK
3/8-16	163 0049
7/16-20	163 0050

THREAD SIZE	BRUSHED FINISH
3/8-16	153 0003
3/8-24	153 0006
7/16-20	153 8510
12mm x 1.75	153 4910 (1)
16mm x 1.50	153 4960 (2)

(1) Mustang
(2) Camaro/Firebird



DIRECT FIT T-HANDLES

- Quality die cast aluminum
- Polished or brushed finish
- Bold HURST identification
- Complete w/ jam nut

THREAD SIZE	POLISHED FINISH	BRUSHED FINISH
3/8-16	153 0026	153 4813
3/8-24	153 0027	153 4758
7/16-20	153 8500	153 8501
12mm x 1.75	--	153 4900 (1)
16mm x 1.50	--	153 4950 (2)

(1) Mustang
(2) Camaro/Firebird



SHIFTER KNOBS & T-HANDLES



THREAD SIZE	BRUSHED FINISH	CHROME FINISH
HURST SAE	153 0019	153 0032
HURST Metric	153 0018	153 0033
INDY SAE	153 8430	--

#153 8430



UNIVERSAL HURST T-HANDLES

- Quality die cast aluminum
- Brushed or chrome finish
- Bold HURST identification
- Complete with adapters & jam nut
- SAE fits 1/4-28, 5/16-18, 3/8-16*, 1/2-20
- Metric fits 7mm x 1.00, 8mm x 1.25, 10mm x 1.50, 12mm x 1.50

* SAE 3/8-16 in Chrome Finish only

#153 0019



UNIVERSAL INDY T-HANDLES

- Quality die cast aluminum
- Brushed finish
- Bold INDY identification
- Complete with adapters & jam nut
- SAE fits 1/4-28, 5/16-18, 3/8-16, 3/8-24, 1/2-20

HURST NASCAR 50TH ANNIVERSARY SHIFTER BALL

- HURST name engraved on the sides
- Measures 2-1/4" Diameter with the NASCAR 50th Anniversary logo
- Black knob features gold emblem, White knob features 4-color emblem
- Universal applications fit 3/8-16 UNC, 5/16-18 UNC, 10mm x 1.50, 12mm x 1.75 and 16mm x 1.50



DESCRIPTION	PART NO.
White knob with 4-color NASCAR 50th Anniversary logo	163 5050
Black knob with gold NASCAR 50th Anniversary logo	163 5055

CUSTOM SHIFT KNOBS

- Sporty, custom look
- Available in a variety of styles
- Easily installed
- Fits all 1/4" through 9/16" shifter handle threads

Also a direct replacement for Camaro and Firebird having 16mm x 1.50 threaded factory shifter stick.



#163 2002

#163 2006

#163 2014

STYLE	Short	Tall
BLACK LEATHER	163 2002	163 2004
CARBON FIBER STYLE	163 2006	--
ALUMINUM BILLET	--	163 2008
LEATHER & CARBON FIBER STYLE	--	163 2012
CARBON FIBER STYLE & ALUMINUM	163 2014	--
LEATHER & BRUSHED CHROME	--	163 2025



#163 2025

#163 2004

#163 2008

#163 2012

THREAD SIZE CHART

Hurst Shifters	Stick Thread Size	Hurst Shifters	Stick Thread Size	OEM Shifters	Stick Thread Size
Aluminum sticks	7/16-20	Indy Pick Up Truck	3/8-24	Camaro 6 speed internal	
Auto/Stick 1	3/8-16	Indy Qualifier	3/8-16	rail w/OEM stick	16mm x 1.50
Auto/Stick 3	3/8-16	Indy SSA	3/8-24	Firebird 6 speed internal	
Billet/Plus w/chrome stick	3/8-16	Pro-Matic, before 1987	1/2-13	rail w/OEM stick	16mm x 1.50
Billet/Plus w/black stick	Factory OE Thread Size	Pro-Matic 2, since 1987	3/8-16	Mustang 5 speed internal	
Chrome replacement sticks	3/8-16	Quarter/Stick & Q/S 2	7/16-20	rail w/OEM stick	12mm x 1.75
Comp/Plus (early)	3/8-24	Quick/Stick	Factory OE Thread Size		
Comp/Plus (late), & OEM	3/8-16	Super Shifter 3	3/8-16	B & M Shifters	
Dual/Gate 2	3/8-16	Vertical Gate, before 1987	1/2-13	Most automatic shifters	1/2-20
Indy 3 Speed	3/8-24	V-Gate 2, since 1987	3/8-16		
Indy Matic 1	3/8-24	V-Matic, before 1987	1/2-13		
		V-Matic 2, since 1987	3/8-16		



SHIFTER BOOTS

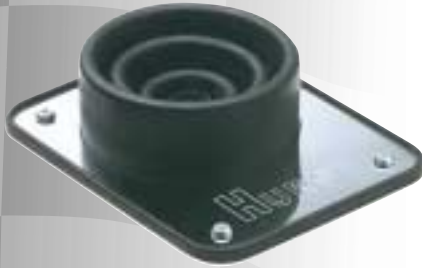

B-1 BOOT & PLATE

Designed for use with round stick shifters. Complete with chrome ID plate and mounting hardware.

Part No.	Measures
114 7336	4-3/8" x 5-1/2"



B-4 BOOT & PLATE

Our most popular boot is adaptable to most shifter installations. Complete with chrome trim plate and mounting hardware.

Part No.	Measures
114 4580	3-1/2" x 4-1/2"



INDY QUALIFIER BOOT & PLATE

Designed for use with Hurst/Indy Qualifier Shifter. Complete with chrome trim plate and mounting hardware.

Part No.	Measures
114 8435	2-1/2" x 3-1/2"



INDY BOOT & PLATE

A popular economy boot. Complete with chrome trim plate and mounting hardware.

Part No.	Measures
114 8429	3-1/2" x 4-1/2"



SUPER BOOT & PLATE

Designed for large hole shifter installations. Complete with chrome ID plate and mounting hardware.

Part No.	Measures
114 7494	7-3/4" x 8-3/4"



V-GATE 2 BOOT & PLATE

Specially designed for use with the V-Gate 2 or Mr. Gasket Vertical Gate 4- & 5-speed shifter which utilizes a trigger operated main stick. Complete with chrome trim plate and mounting hardware.

Part No.	Measures
114 1653	8-1/4" x 12-1/8"

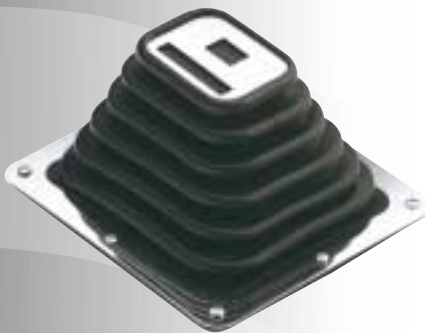

SUPER/SHIFTER 3 BOOT & PLATE

Specially designed for use with Super/Shifter 3 utilizing separate reverse Loc/Out lever. Complete with chrome trim plate and mounting hardware.

Part No.	Measures
114 0010	7-3/4" x 8-3/4"



REPLACEMENT BOOT

For use as replacement for all die cast aluminum internal rail shifters.

Part No.	Measures
114 0024	5" x 3-3/4"



REPLACEMENT BOOT

Used on most Billet/Plus shifters.

Part No.	Measures
114 5001	3" I.D. Round Base

HURST TRANSMISSION LOCK-UP HARNESS

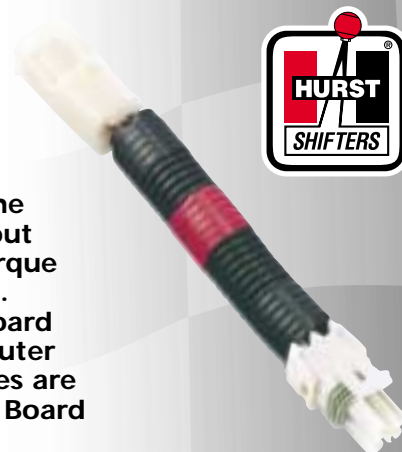

This transmission lock-up harness increases performance by delaying the operation of the torque converter clutch and eliminating annoying in/out engagement of the torque converter. By delaying the lock-up of the torque converter, torque multiplication and vehicle performance are increased. These kits are easily installed and will not interfere with existing on-board computer TPS or MAP sensor signals. Available for most 1981-95 computer controlled GM vehicles (FWD/RWD), Hurst transmission lock-up harnesses are legal to sell and install in California under the California Air Resources Board Executive Order #D-345.

Vehicle	Year	Transmission	Part No.
BUICK			
	1981-92	125C	*
Century	1985-86	440-T4 (OD)	155 0015
	1987	440-T4 (OD)	155 0025
	1988-92	440-T4 (OD)	155 0020
Electra	1981-84	200-4R	155 0015
	1981-89	200-4R	155 0015
EstateWagon	1990-92	700-R4	155 0010
	1985-86	440-T4	155 0015
LeSabre	1987	440-T4	155 0025
	1988-90	440-T4	155 0020
	1985-86	440-T4	155 0015
Park Avenue	1987	440-T4	155 0025
	1988-90	440-T4	155 0020
	All	440-T4	155 0020
Regal RWD	1981-87	200-4R	155 0015
Regal FWD	1988-92	440-T4	155 0020
Riviera	1981-85	325-4L	155 0015
	1986-89	440-T4	155 0020
Skyhawk	1981-90	125C	*
Skylark	1981-90	125C	*
Somerset	1985-95	125C	*
CADILLAC			
Brougham	1981-89	700-R4	155 0015
	1990-91	700-R4	155 0010
Cimarron	1982-89	125C	*
Deville	1985-89	440-T4	155 0020
Eldorado	1981-85	325-4L	155 0015
	1986-89	440-T4	155 0020
Seville	1981-85	325-4L	155 0015
	1986-89	440-T4	155 0020
CHEVROLET			
Astro Van	1985-92	700-R4	155 0010
Beretta	1988-95	125C	*
	1988-92	440-T4	155 0020
Blazer	1982-92	700-R4	155 0010
Camaro	1981-89	700-R4	155 0015
	1990-92	700-R4	155 0010
Caprice	1981-89	700-R4	155 0015
	1990-92	700-R4	155 0010
Cavalier	1981-94	125C	*
	1981-92	125C	*
	1985-86	440-T4	155 0015
Celebrity	1987	440-T4	155 0025
	1988-92	440-T4	155 0020
	1988-95	125C	*
Corsica	1988-92	440-T4	155 0020

Vehicle	Year	Transmission	Part No.
CHEVROLET (continued)			
Corvette	1981-89	700-R4	155 0015
	1990-91	700-R4	155 0010
Lumina	1990-95	125C	*
Monte Carlo	1981-87	700-R4	155 0015
S-10 Pickup	1982-92	700-R4	155 0010
Suburban	1982-87	700-R4	155 0015
	1988-92	700-R4	1550010
	1982-87	700-R4	155 0015
Pickup Truck	1988-92	700-R4	155 0010
	GMC		
Jimmy	1982-92	700-R4	155 0010
S-15 Pickup	1982-92	700-R4	155 0010
Safari Van	1985-92	700-R4	155 0010
Suburban	1982-87	700-R4	155 0015
	1988-92	700-R4	155 0010
Full Size Van & Pickup Truck	1982-87	700-R4	155 0015
	1988-92	700-R4	155 0010
OLDSMOBILE			
Achieva	1992-95	125C	*
Calais	1985-91	125C	*
	1981-95	125C	*
Ciera	1987	440-T4	155 0025
	1988-92	440-T4	155 0020
Cutlass(RWD)	1981-84	200-4R	155 0015
	1981-84	200-4R	155 0015
88/98 (RWD)	1985-86	440-T4	155 0015
	1987	440-T4	155 0025
	1988-90	440-T4	155 0020
88/98 (FWD)	1982-88	125C	*
	1990-95	125C	*
Firenza	1982-88	125C	*
Silhouette Van	1990-92	440-T4	155 0020
	1981-85	325-4L	155 0015
Toronado	1986-89	440-T4	155 0020
PONTIAC			
Bonneville(FWD)	1987	440-T4	155 0025
	1988-90	440-T4	155 0020
Firebird	1981-89	700-R4	155 0015
	1990-92	700-R4	155 0010
Grand Am	1985-95	125C	*
	1981-93	125C	*
6000	1987	440-T4	155 0025
		440-T4	155 0020
Sunbird	1982-93	125C	*
	1990-95	125C	*
	1990-92	440-T4	155 0020
Transport	1990-92	440-T4	155 0020
	1990-92	700-R4	155 0010

* 125C Transmissions:

White male connector, 3 wire
Black male connector, 4-wire
Blue male connector, 2-wire

Part #155 0030
Part #155 0033
Part #155 0036

NOTE: All applications are 3-wire computer-controlled ONLY, except 125C transaxles where indicated. Not available for diesel-equipped vehicles.



HOT SHIFT™ 2 & 3

HIGH PERFORMANCE SHIFT MODIFYING KITS

Hot Shift 2 and Hot Shift 3 are the best way to modify the shift patterns of automatic transmissions for optimum performance. Along with the legendary Hurst name, automatic transmission owners can now enjoy quicker, more precise shifts, lower operating temperatures, and increased overall transmission efficiency.



Hot Shift 2

- Heavy-Duty: provides a firm shift without any harshness.
- Street-Strip: for tire chirping shifts. Ideal for the hi-performance enthusiast on a budget.



Hot Shift 3

- Heavy-Duty: firm shifts, ideal for towing, fleet use, RV, or everyday street use
- Street-Strip: provides a much harder instantaneous shift, while retaining the automatic shifting capabilities.
- Race Only: for all out racing only! Extremely hard shifts. Not suitable for street use.

Note: To be used on vehicles with NON-Lock up Torque Converters.

A P P L I C A T I O N S

Transmission	Year	HOT SHIFT 2		HOT SHIFT 3	
		Part No.	Part No.	Part No.	Part No.
GM TH 350	68-81	285 8601	285 8611		
GM TH 400	65-87	285 8602	285 8612		
Ford C-6	67-91	285 8630	285 8640		
Mopar A727/904	71-77	285 8660			—

ACCESSORIES



HOT SHIFT™ ATF FLUID

Formulated to improve the performance of all automatic transmissions, including high performance street and race cars, passenger cars, light trucks and recreational vehicles. Hurst Hot Shift Fluid is the most advanced, custom blended automatic transmission fluid available today. This exclusive formula combines friction modifiers, extreme pressure additives and anti-foaming agents to produce quicker, firmer and more positive shifts, while providing maximum protection to all transmission components. This fluid is so effective in reducing friction that your transmission will actually run cooler. So "Cool It Down" with Hot Shift Fluid from Hurst and put the heat where it belongs...on the competition.



Hot Shift Fluid 1 quart - Part No. 180 1000

AUTOMATIC TRANSMISSION SWAP KITS FOR CAMARO, FIREBIRD

Installing a Turbo-Hydro 350 or 400 in your '82-'91 Camaro or Firebird has just been made easier with a new transmission swap kit from Hurst Performance. Designed to assist in replacing the stock automatic or manual transmission in V8 applications, these kits eliminate having to fabricate custom brackets and adapters, allowing for a relatively hassle-free, bolt-in installation. Note: Though no additional fabrication is required to make the swap, the driveshaft must be shortened to accommodate the TH 400 transmission and a TH 400 front yoke must be used. Each kit is complete with a new torque arm bracket, two transmission arms, cable brackets, spacers and related hardware. The TH 400 kit includes a new transmission crossmember assembly while the TH 350 kit utilizes the stock OEM crossmember.



'82-'91 CAMARO/FIREBIRD	
Transmission	Part No.
TH 350	550 0001
TH 400	550 0002

AUTOMATIC TRANSMISSION DRAIN PLUG

This universal oil drain plug can be used on most automatic transmission oil pans. It makes oil changes possible without dropping the oil pan. Requires a 1/2" diameter hole for installation. Complete with instructions and brass plug for convenient sealing. Part No. 285 4470





SERVICE PARTS

AUTO/STICK 3, Automatic Shifter - Cable Operated

Part Number	Shifter	Cable Bracket	Neutral Switch	Cable	Console	Console Plate	Pattern Label	Tee Handle	Cable Bracket	Cable Bracket GM	Cable Bracket Chrys.	Trans Arm	Inst. Sheet	Bagged Hdwr.
383 0012	383 0005	117 0092	248 0003	500 0025	129 0003	195 0122	241 0002 Std. Pattern 241 0003 Rev. Pattern	153 4813	117 5711	117 0094	117 0037 (C-4) 117 0038 (C-6)	105 0080 105 0082 105 0081	159 0155	154 0128

DUAL/GATE 2 CUSTOM FIT FOR CAMARO, FIREBIRD

Part Number	Front Bracket	Rear Bracket	Lens Shift Indicator	Escutcheon	Knob	Bagged Hdwr.	Inst. Sheet
292 0000	117 4768	117 4773		140 0009	163 7200	154 8390	159 1034

DUAL/GATE 2, Automatic Shifter - Cable Operated

Part Number	Shifter Only	Front Bracket	Rear Bracket	Trans Arm	Lamp Housing	Bulb Socket	Cable	Pattern indicator	Console	Console Plate	Cable Bracket	Bagged Hdwr.
292 0006	292 0003	117 0144	117 0145	105 0080 105 0082	157 0126	166 0002	500 0025	241 0004	129 0009	195 0140	117 5711 117 4778Z	154 0136 154 0137
292 0007	292 0004	117 0144	117 0145	105 0081 105 0081	157 0126	166 0002	500 0025	241 0004	129 0009	117 0037 117 0038	117 0094	154 0137

INDY MATIC

Part Number	Shifter Assy.	Arm Chevrolet Mercomatic	Arm Fordomatic Cruisomatic	Arm Fordomatic Oldsmobile	Arm Pontiac Oldsmobile	Arm Pontiac	Rods	Inst. Sheet
506 0001	506 0003	105 0007	105 0008	105 0009	105 0011	105 0012 213 0012 - bent	213 0011 - straight	159 0022

INDY 3-SPEED SHIFTER AND INSTALLATION KIT

Part Number	Shifter Ass'y.	Mounting Bracket	Stiffener Brace	Arm 1 & Rev.	Arm 2 & 3	Rod 1 & Rev.	Rod 2 & 3	Bagged Hardware	Bagged	Inst. Sheet
501 0002	501 0004	117 0212	116 0001	105 0005	105 0004	213 0002	213 0003	154 0110	154 0002	159 0876 159 0129
501 0016	501 0017	117 0212	116 0001	105 0005	105 0005	213 0190	213 0214 213 0192	154 0110	154 0176	159 0129 159 1001
501 0018		117 0212	116 0001	105 0005	105 0005	213 0002	213 0209 213 0190	154 0110	154 0189	159 0129 159 1021

INDY FOUR-SPEED SHIFTER AND INSTALLATION KIT

Part Number	Shifter w/o Stick	Stick	Mounting Plate	Arm 1 & 2	Arm 3 & 4	Arm Rev.	Rod 1 & 2	Rod 3 & 4	Rod Rev.	Bagged Hardware	Inst. Sheet
503 0030	503 0024	238 0077	195 0037	105 2140 105 7058	105 7075 105 2141 105 7060	105 0055 105 0052	213 7803	213 0079	213 7819 213 1699	154 7813	159 0125
503 0031	503 0024	238 0077	195 8382	105 8383	105 2141	105 7647	213 8377	213 8378	213 8379	154 8374	159 0126
503 0032	503 0024	238 0077	195 2298	105 4829	105 3894	105 3832	213 1588	213 8003	213 8037	154 8006	159 0127
503 0033	503 0024	238 0077	117 0084 116 0010	105 4293	105 4294	105 0016	213 0037	213 0039	213 0038	154 0116	159 0128

SERVICE PARTS



PRO-MATIC 2 & V-MATIC 2, Automatic Shifter - Cable Operated

Part Number	Trans Model	Cable Bracket	Console Black	Console Cover Chrome	Boot Plate Chrome	Indicator Lens Cover	Neutral-Safety Back-Up Switch	Rubber Boot	Shifter Cable	Trans Arm	Trigger Polished
383 8500	TH 250 & 350	117 8562								105 8561	
	TH 400	117 8560								105 8561	
	C 6	117 8557	129 8554	195 8551	--	241 8552 (Forward Body)	248 0021	114 8550	500 8555	105 8559	--
	C 4	117 8558				241 8567 (Reverse Body)				105 8559	
383 8504	A 727 & 904	117 8563								105 8564	
	TH 700 R4	117 4778Z	129 8554	195 8551	--	169 0005	248 0021	114 8550	500 8555	105 8567	--
383 8505	TH 200 4R	117 4778Z								105 8572	--
	Powerglide	117 8565	129 8554	195 8551	--	241 8553	248 0021	114 8550	500 8555	105 8566	--
383 8510	TH 250 & 350	117 8562								105 8561	
	TH 400	117 8560								105 8561	
	C 6	117 8557	129 8554	195 8551	--	241 8552	248 0021	114 8550	500 8555	105 8559	--
	C 4	117 8558								105 8559	
383 8511	A 727 & 904	117 8563								105 8564	
	TH 700 R4	117 4778Z	129 8554	195 8551	--	169 0005	248 0021	114 8550	500 8555	105 8567	--
383 8515	TH 200 4R	117 4778Z								105 8572	--
	TH 250 & 350	117 8562	--	--	195 8574	241 8570 (Forward Body)	248 0021	114 8572	500 8555	105 8561	307 8576
383 8520	TH 400	117 8560								105 8561	
	C 6	117 8557	129 8554	--	195 8574	241 8570	248 0021	114 8572	500 8555	105 8559	307 8576
	C 4	117 8558								105 8559	
	A 727 & 904	117 8563								105 8564	
383 8521	TH 700 R4	117 4778Z	129 8554	--	195 8574	169 0006	248 0021	114 8572	500 8555	105 8567	307 8576
	TH 200 4R	117 4778Z								105 8572	
383 8525	Powerglide	117 8565	--	--	195 8574	241 8571	248 0021	114 8572	500 8555	105 8566	307 8576
383 8530	TH 250 & 350	117 8562	--	--	195 8574	241 8570	248 0021	114 8572	500 8555	105 8561	307 8576
	TH 400	117 8560								105 8561	
383 8531	TH 250 & 350	117 8562	--	--	195 8574	241 8570	248 0021	114 8572	500 8555	105 8561	307 8576
	TH 400	117 8560								105 8561	



REPLACEMENT SHIFTER SPRINGS

Restore precise shifter action by replacing the weak or damaged springs in the Pro-Matic, V-Matic or Billet/Plus shifters. The Pro-Matic and V-Matic kit includes 1 of each centering, ratchet and position springs, part #230 8500. The Billet/Plus kit includes two of each inner and outer bias springs, part #230 5000.

QUARTER STICK, Automatic Shifter - Cable Operated

Part Number	Trans Model	Shifter Only	Cable Bracket	Trans Arm	Cable	Console	Inst. Sheet
316 0001	Powerglide		117 0095	105 0084			
	TH 200, 350, 375, 400	316 0003	117 4778Z	105 0080	500 0025	130 0041	159 0999
316 0006	TH 200, 350, 375, 400	316 0008	117 4778Z	105 0080	500 0025	130 0041	159 1004
	C-6		117 0038	105 0081			
316 0009	C-4	316 0011	117 0037	105 0081	500 0025	130 0041	159 1004
	A727-904		117 0094	105 0082			
316 0014	A727-904		117 0094	105 0082			
	C-4	316 0017	117 0037	105 0081	500 0025	130 0041	159 1018
	C-6		117 0038	105 0081			
316 0016	TH 250, 350, 375, 400	316 0018	117 4778Z				
			117 0199	105 0059	500 0025	130 0041	159 1009
316 0020	Powerglide		117 0098	105 7000			
	TH 250, 350, 375, 400	316 0021	117 0099	105 0098	500 0025	130 0056	159 0998
			117 0099	105 0098			
316 0025	Powerglide	316 0026	117 0098	105 7000	500 0025	130 0056	159 0998
316 0030	TH 700 R4	316 0088	117 4778Z	105 0080	500 0025	140 0020	159 1032
316 0082	TH 700 R4	316 0019	117 4778Z	105 0080	500 0029		159 1010
316 0083	TH 700 R4	316 0087	117 4778Z		500 0029		159 1033



SERVICE PARTS

COMPETITION/PLUS, 4-Speed Installation Kits

Installation Kit	Mounting Plate	Arm 1 & 2	Arm 3 & 4	Arm Reverse	Rod 1 & 2	Rod 3 & 4	Rod Reverse	Bagged Hardware	Bagged Hardware	Instruction Sheet
373 0017	195 0125	105 4293	105 4294	105 4295	213 0136	213 0137	213 0135	154 0131	-	159 0168
373 0021	195 0199(1)	105 0043	105 0044	105 2489	213 0163	213 0164	213 0165	154 0174	-	159 0997
373 0022	195 0199(1)	105 4293	105 4864	105 4295	213 0193	213 0194	213 0195	154 0178	-	159 1003
373 3157	195 7773	105 2140	105 2141	105 1670	213 2144	213 2145	213 2146	154 3151	154 0073(21)	159 0181
373 3162	195 8008	105 2440	105 2441	105 2445	213 2144	213 2145	213 2439	154 4097	154 0071(21)	159 0269
373 3163	195 7773	105 2440	105 2441	105 2442	213 2438	213 2139	213 3404	154 3151	154 0071(21)	159 0274
373 3164	195 2482	105 2140	105 2488	105 2489	213 2486	213 2485	213 2487	154 3152	154 0071(21)	159 0279
373 3165	195 2722	105 2723	105 2724	105 2725	213 2726	213 2727	213 2728	154 3153	154 0071(21)	159 0307
373 3166	195 2816	105 2140	105 2141	105 1670	213 2814	213 2815	213 2444	154 3154	154 0071(21)	159 0391
373 3167	195 2816	105 2723	105 2724	105 3698	213 3691	213 2774	213 3695	154 3154	154 0071(21)	159 0381
373 3668	195 3176	105 3665	105 3666	105 3667	213 2758	213 3172	213 2137	154 3183	-	159 0375
373 4089	195 6348(1)	105 3894	105 3831 105 3667	105 2445	213 4164	213 3830	213 3189	154 4088	154 0071(21)	159 0412
373 4297	195 4204	105 4293	105 4294	105 4295	213 4187	213 4188	213 4335	154 4242	154 0071(21)	159 0425
373 4354	195 4345	105 4346	105 2441	105 4347	213 4348	213 1588	213 2487	154 4353	154 0071(21)	159 1042
373 4529	117 5284(3)	105 5286	105 5287	105 2445	213 5307	213 2145	213 3691	154 5289	154 0071(21)	159 0464
373 4531	117 5284(3)	105 4293	105 4294	105 4295	213 5298	213 5299	213 5308	154 5289	154 0071(21)	159 0463
373 4648	195 8008	105 2440	105 2441	105 2445	213 2144	213 2145	213 2146	154 4097	154 0071(21)	159 0598
373 4734	195 7773	105 2140	105 2141	105 2142	213 2138	213 2139	213 3404	154 3151	154 0071(21)	159 0181
373 5587	117 6889 195 6834	105 2723	105 2108	105 2725	213 1720	213 2774	213 3207	154 4197	-	159 0344
373 6819	195 0165(1)	105 5286	105 2656	105 2442	213 2920	213 4769	213 6818	154 0163 154 6821	154 0071(21)	159 0676 159 0981
373 7131	117 5284(3)	105 7129	105 7130	105 7128	213 5307	213 2145	213 3691	154 5289	154 0071(21)	159 0765
373 7437	195 0164(1)	105 7129	105 7130	105 7128	213 5307	213 2145	213 3691	154 0162 154 6821	154 0071(21)	159 0796
373 7637	195 3176	105 2723	105 2108	105 7647	213 1720	213 2774	213 3207	154 3183	-	159 0802
373 7638	195 4120	105 2723	105 2108	105 7646	213 4146	213 2774	213 4147	154 4197	-	159 0801
373 7717	195 7719(4)	105 2723	105 2108	105 7647	213 1720	213 2774	213 3207	154 3183	-	159 0802
373 7823	195 0165(1)	105 7129	105 4294	105 7825	213 2920	213 4769	213 6818	154 6821	154 0071(21)	159 0812
373 7834	195 7773	105 7058	105 7060	105 7059	213 2438	213 2139	213 3404	154 3151	154 0071(21)	159 0813
373 7897	195 0163	105 7129	105 7130	105 7899	213 3646	213 2139	213 2137	154 6821	154 0071(21)	159 0822
373 7919	117 4208(6)	105 4293	105 4294	105 7923	213 4187	213 4188	213 4335	154 7922	-	159 0823

- 1. Spacer plate195 4319
- 3. U-Bolt265 5293
- 4. Bracket117 6889
- 5. Stick Spacer228 8397
- 6. U-Bolt265 4388
- 7. Back-drive rod213 0030
- 21. Stick Bolts and Stop Bolts154 0071

SERVICE PARTS



COMPETITION/PLUS, 4-Speed Installation Kits (Continued)

Installation Kit	Mounting Plate	Arm 1 & 2	Arm 3 & 4	Arm Reverse	Rod 1 & 2	Rod 3 & 4	Rod Reverse	Bagged Hardware	Bagged Hardware	Instruction Sheet
373 8604	117 4208(6)	105 4293	105 4294	105 4295	213 4187	213 4188	213 4335	154 7922	-	159 0061
373 8605	195 0163(1)	105 7129	105 7130	105 7899	213 3646	213 2139	213 2137	154 6821	-	159 0070
373 8607(7)	195 8008	105 4293	105 4294	105 0016	213 5298	213 5299	213 5307	154 4097	154 0071(21)	159 0075
373 8608	195 0165(1)	105 7129	105 4294	105 7825	213 2920	213 4769	213 6818	154 6821	-	159 0981
373 8609	195 0065(1)	105 2440	105 2441	105 0028	213 4646	213 2139	213 6818	154 0061	154 0071(21)	159 0083
373 8611	195 8008	105 7058	105 7060	105 7061	213 0046	213 2145	213 2146 213 4147	154 0070	154 0074(21)	159 0089
373 8613	195 2298	105 2141	105 0049	105 3667	213 2815	213 2145	213 0078	154 8006	-	159 0120
373 8615	195 8382	105 8383	105 2141	105 7647	213 8377	213 8378	213 8379	154 8374	-	159 0135
373 8616	195 0037	105 2140 105 7058	105 2141 105 7060	105 0052 105 0055 105 7075	213 7803	213 0079	213 1699 213 7819	154 0081 154 7813	-	159 0136
373 8617	195 2298	105 4829	105 3894	105 3832	213 1588	213 8003	213 8037	154 8006	-	159 0137
373 8618	117 0084 116 0010	105 4293	105 4294	105 0016	213 0037	213 0039	213 0038	154 0116	-	159 0139
373 8620	117 0158	105 3894	105 0070	105 0073	213 0152	213 1588	213 0153	154 0150	-	159 0938
373 8621	195 0148	105 2440	105 2441	105 2445	213 0046	213 2145	213 0151	154 4097	-	159 0925

- | | |
|-------------------------------|--|
| 1. Spacer plate195 4319 | 5. Stick Spacer228 8397 |
| 3. U-Bolt265 5293 | 6. U-Bolt265 4388 |
| 4. Bracket117 6889 | 7. Back-drive rod213 0030 |
| | 21. Stick Bolts and Stop Bolts154 0071 |

COMPETITION/PLUS, Shifter & Stick Assemblies

Shifter	Shifter w/o Stick	Stick only	Shifter	Shifter w/o Stick	Stick only
391 0001	391 5401	538 4331	391 3180	391 0014*	-
391 0002	391 5403	538 4331	391 3780	391 0011*	-
391 0024	391 8394	538 0085	391 4339	391 4340	538 4106
391 0027	391 5401	538 0060	391 6789	391 4076	538 4078
391 0028	391 5405	538 0131	391 6822	391 6817	538 6836
391 0029	391 0040	538 0201	391 6848	391 5401	538 6836
391 0030	391 0038	538 0197	391 7307	391 5401	538 7236
391 0031	391 0041	538 0202	391 7308	391 5403	538 7236
391 0032	391 0037	538 0196	391 7438	391 4340	538 7436
391 0033	391 0040	538 0090	391 7535	391 5401	538 7238
391 0035	391 0051	538 8550	391 7930	391 8394	538 7236
391 0036	391 0051	538 8550	391 7960	391 5405	538 7238
391 0060	391 0056	538 8570	391 7992	391 5403	538 7991
391 0061	391 0057	538 8571	391 8014	391 8010	538 8009
391 0070	391 0069	538 0197	391 8789	391 8787	538 6836
391 0110	391 0119	538 0290	391 8791	391 7879	538 8009
391 0120	391 0119	538 0291	391 8792	391 8793	538 6836
			391 8794	391 5401	538 8009

* Includes welded stick, not available separately.



SERVICE PARTS

LIGHTNING RODS FOR LENCOS

Description	Part No.	Part No.	Part No.	Part No.	Part No.	Part No.
	384 0012	384 0002	384 0013	384 0003	384 0016	384 0006
Shifter Only	384 0014	384 0004	384 0015	384 0005	384 0017	384 0007
Installation Kit	373 0018	373 0018	373 0019	373 0019	373 0020	373 0020
Bagged Hdwr.	154 0171	154 0171	154 0171	154 0171	154 0171	154 0171
					154 0173	154 0173
Arms	1-105 0090	1-105 0090	3-105 0089	3-105 0089	1-105 0090	1-105 0090
	2-105 0089	2-105 0089			2-105 0089	2-105 0089
Arm Reverse	105 0074	105 0074	105 0074	105 0074	105 0074	105 0074
Rods	17" - 213 0173	17" - 213 0173	22" - 213 0173	22" - 213 0173	10" - 213 0189	10" - 213 0189
	9" - 213 0175	9" - 213 0175	14" - 213 0169	14" - 213 0169	8.5" - 213 0177	8.5" - 213 0177
	2" - 357 0028	2" - 357 0028	6" - 213 0171	6" - 213 0171	3.75" - 357 0029	3.75" - 357 0029
Reverse Rod	213 0162	213 0162	213 0161	213 0161	213 0089	213 0089
Mounting Plate	195 0167	195 0167	195 0168	195 0168	--	--
Clamp Assembly	126 0015	126 0015	126 0015	126 0015	126 0015	126 0015
Detent Disc	134 0004	134 0004	134 0003	134 0003	134 0003	134 0003
Link	171 0016	171 0016	171 0016	171 0016	171 0016	171 0016
Pin 1/4"	189 0071	189 0071	189 0071	189 0071	189 0071	189 0071
Pin 5/16"	189 0070	189 0070	189 0070	189 0070	189 0070	189 0070
Knob	163 0034	163 0034	163 0034	163 0034	163 0034	163 0034
Instruction Sheet	159 0996	159 0996	159 0996	159 0996	159 0996	159 0996

MASTERSHIFT, 3-Speed Installation Kits

Installation Kit	Mounting Bracket	Stiffener Brace	Arm L-R	Arm 2 & 3	Rod L & R	Rod 2 & 3	Bagged Hardware	Bagged Hardware	Inst. Sheet	Misc. - See Footnotes
367 0006	117 0044 117 0045	116 0007	105 7135	105 7130	213 0024	213 0025	154 0053	154 0071(21)	159 0063	16
367 0012	117 0061 117 0062	116 0017	105 0035 105 0054	105 0036 105 0056	213 4093	213 0058	154 0076	154 0071(21)	159 0100	10
367 0013	117 0007	116 0004 117 4777	105 4746	105 4747	213 4742 213 0062	213 4741 213 0063	154 0025	154 0071(21)	159 0101	10-16
367 0014	117 0071	116 0021	105 1573	105 2108	213 2001	213 0066	154 0095	-	159 0110	10
367 0023	117 0062 117 0061	116 0016	105 0031 105 0057	105 0032 105 0058	213 0058	213 3601	154 0076	-	159 0156	-
367 0025	117 0097 117 0096	116 0025	105 4864	105 4865	213 0080	213 1588	154 0130	-	159 0166	10
367 0027	117 0151	116 2319	105 7656	105 2320	213 2321 213 1562	213 2322 213 0147	154 0013	-	159 0927	10
367 3111	117 7154	116 7153	105 1526	105 1550 105 1657	213 2007	213 2008	154 0016	154 0071(21)	159 0020	10-16
367 3112	117 8227	116 1734	105 1526	105 1550	213 1735 105 1657	213 1736	154 0009	154 0071 (21)	159 0003	10-16
367 7143	117 8228	-	105 7144	105 4864	213 4209	213 4210	154 0010	154 0071(21)	159 0014	10-6-16
367 7640	195 3176	-	105 7645	105 1779	213 2758	213 3172	154 0024	154 0071(21)	159 0017	10-16

MASTERSHIFT, Shifter & Stick Assemblies

Shifter	Shifter w/o Stick	Stick only	Shifter	Shifter w/o Stick	Stick only
366 0010	366 0001	538 0060	366 6809	366 0001	538 4331
366 0014	366 0001	538 0085	366 6901	366 0001	538 6900
366 3179	366 0008	-	366 7271	366 0001	538 7236

SERVICE PARTS



RICHMOND 5-SPEED SHIFTER AND INSTALLATION KIT

Part Number	Shifter w/o stick	Stick	Shifter Plate	Arm 1 & 2	Arm 3 & 4	Arm 5th Rev.	Rod 1 & 2	Rod 3 & 4	Rod 5th Rev.	Bagged Hdwr.	Instruction Sheet
407 0009	407 0010	538 1000	195 0133	105 0043	105 0043	105 0043	213 0143	213 0144	213 0145	154 0109	159 0177
407 0015	407 0010	538 7238	195 0133	105 0043	105 0043	105 0043	213 0143	213 0144	213 0145	154 0109	159 0177

SUPER/SHIFTER 3 & SPEEDWAY SUPER/SHIFTER, 4-Speed Installation Kits

Installation Kit	Mounting Plate	Arm 1 & 2	Arm 3 & 4	Arm Reverse	Rod 1 & 2	Rod 3 & 4	Rod Reverse	Bagged Hardware	Instruction Sheet
373 0006	195 0037	105 0023	105 0024	105 0055 105 7075	213 0071	213 0072	213 0084	154 0117	159 0141
373 0007	195 0037	105 7058	105 7060	105 7075	213 0071	213 0072	213 0084	154 0117	159 0141
373 0011	117 4819	105 4828	105 4829	105 0053	213 0106	213 0100	213 0096	154 0121	159 0144
373 0014	195 8382	105 8383	105 2141	105 7647	213 0110	213 0105	213 0101	154 0119	159 0147
373 0024	195 0222	105 0085	105 0086	105 0087	213 0197	213 0198	213 0200	154 0182	159 1008
373 0025	195 0222	105 0094	105 0095	105 0093	213 0205	213 0198	213 0206	154 0182	159 1008

SUPER/SHIFTER 3 & SPEEDWAY SUPER/SHIFTER, Shifter & Stick Assemblies

	Shifter	Shifter w/o Stick	Stick Only
Super/Shifter 3	491 0001	491 0002	538 7238
Speedway Super/Shifter	491 0004	391 0039	-

V-GATE 2, Installation Kit

Installation Kit	Mounting Plate	Arm 1 & 2	Arm 3 & 4	Arm Reverse	Rod 1 & 2	Rod 3 & 4	Rod Reverse	Bagged Hdwr.	Inst. Sht.
373 8164	195 9045	105 8026	105 8025	105 8016	213 6102	213 6104	213 6134	154 8164	159 8164
373 8165	195 9037	105 8030	105 8031	105 8006	213 6162	213 6104	213 6135	154 8165	159 8165
373 8171	195 9026	105 8038	105 8032	105 8000	213 6109	213 6110	213 6126	154 8171	159 8171
373 8172	195 9026	105 8038	105 8032	105 8039	213 6111	213 6112	213 6113	154 8172	159 8172
373 8174	195 9026	105 8039	105 8032	105 8040	213 6117	213 6106	213 6127	154 8174	159 8174
373 8175	195 9044	105 8038	105 8032	105 8000	213 6118	213 6110	213 6126	154 8175	159 8175
373 8180	195 9038	105 8028	105 8029	105 8006	213 6100	213 6103	213 6123	154 8180	159 8180
373 8182	195 9034	105 8028	105 8029	105 8006	213 6102	213 6104	213 6125	154 8182	159 8182
373 8188	195 9037	105 8030	105 8031	105 8031	213 6163	213 6164	213 6106	154 8188	159 8188
373 8190	195 9037	105 8039 (T-10) 105 8026 (*69 & up Mun) 105 8030 (Pre '69 Mun)	105 8032(T-10) 105 8025 (*69 & up Mun) 105 8031 (Pre '69 Mun)	105 8006(T10) 105 8027 (*69 & up Mun) 105 8041 (Pre '69 Mun)	213 6102	213 6104	213 6124 213 6120	154 8190	159 8190
373 8193	195 8657	105 8573	105 8574	105 8575	213 8697	213 8698	213 2322	154 8193	159 8193

ROLL CONTROL

Part Number	Switch Assy.	Indicator Light w/o Bulb	Solenoid Valve 12V	Instructions	Rebuild Kit No.
174 5000	248 3875	188 7125	566 7550	159 0394	567 1500



SERVICE PARTS

SHIFTER CABLES

Replacement shifter cables are available for all Hurst automatic shifters. Additionally, several lengths of cables are available for the Quarter Stick and Pistol Grip shifters. These premium quality cables feature a solid 303 Stainless Steel inner wire core encased within a nylon liner wrapped with helical lay wires and swaged ends for superior strength. The core is lubricated with Teflon prior to assembly and then sealed in a heavy plastic outer casing for a lifetime of durability and smooth operation.



#500 0029

Standard Replacement Cables	Part No.
-----------------------------	----------

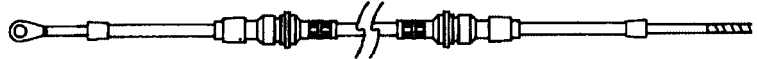

Auto Stick 3, Pistol Grip, Q-Stick/Q-Stick 2, Lightning Rods, Pick-up Truck Auto stick, Dual Gate 2, Van Auto Stick 500 0025

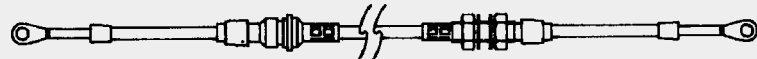

Q-Stick (Late model Camaro, Monte Carlo) 500 0029

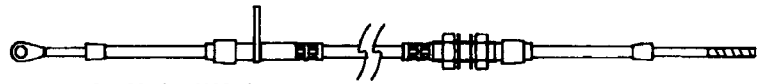

Pro Matic 2, V-Matic 2 500 8555

Part No.	Cable Length
500 0023	3 ft. Adjustable Single Eyelet
500 0024	4 ft. Adjustable Single Eyelet
500 0025*	5 ft. Adjustable Single Eyelet
500 0028	8 ft. Adjustable Single Eyelet
500 0020	11 ft. Adjustable Single Eyelet
500 0029**	5 ft. Adjustable Double Eyelet
500 8555***	5 ft. Adjustable Single Eyelet

IMPORTANT: Make sure the cable is not kinked, bent in too tight of a radius, touching the exhaust manifold or dragging the ground. If this occurs, make the adjustment to eliminate the problem.

* Standard cable for most Quarter Stick shifters.

** Standard cable for Quarter Stick shifters No.s 316 0082, 316 0083

*** Standard cable for the Pro Matic 2 and V-Matic 2.

Also used as a replacement for B&M cable No. 80605.



REPLACEMENT SHIFTER SPRINGS

Restore precise shifter action by replacing the weak or damaged springs in the Pro-Matic, V-Matic or Billet/Plus shifters. The Pro-Matic and V-Matic kit includes 1 of each centering, ratchet and position springs. Part No. 230 8500

The Billet/Plus kit includes two of each inner and outer bias springs. Part No. 230 5000



SUPER/SHIFTER 3 PIT PACK

This pit pack is designed specifically for the Super/Shifter 3. Kit includes 6 each of steel bushings, locking tabs and locknuts for use on "bolt-on" linkage rods. (Also fits Ram Rod shifters). Part No. 332 0002



HURST PIT PACKS

Available in either steel or nylon. Steel bushings are designed to take the punishment of racing applications and provide for longer service. Nylon bushings are designed for street applications and eliminate most of the stick vibrations. These pit packs can be used on the Master Shift 3-Speed, Competition Plus 4-Speed and the V-Gate 2. Kit includes either 7 steel or nylon bushings and spring clips.

Part No.	Application	Description
332 0001	3-, 4-, & 5-speed manuals	Nylon bushings
332 7302	3-, 4-, & 5-speed manuals	Steel bushings
154 3398	3-, 4-, & 5-speed manuals	Steel bushings (Bulk 100 pcs.)
332 1657	V-Gate 2 only	Steel bushings

* Pit Packs should be replaced every 2-3 years for optimum performance.

ROD BUTTONS/OE REPLACEMENTS

Part No.	Application	Description
119 8060	Competition/Plus Rod Button	2 per pack
119 0002	Super/Shifter 3 Rod Button	1 per pack
119 8057PO	Indy 3-speed Shifters Rod Button	1 per pack
280 7186	OE Rubber Grommet - GM	1 per pack
280 0001	OE Rubber Grommet - Ford	1 per pack
126 3705	Stick Clamp/OE Shifters	1 per pack
161 3706	Stick Isolator/OE Shifters	1 per pack

SHIFTER STICKS

LIGHT WEIGHT ALUMINUM STICKS

Hurst aluminum shifter sticks are more resilient than steel in competition use, and are one-third lighter. 2024 aluminum heat treated to T-6. Ultimate tensile strength 68,000 psi. All aluminum sticks incorporate a 7/16 - 20 thread size.



NATURAL ALUMINUM FINISH

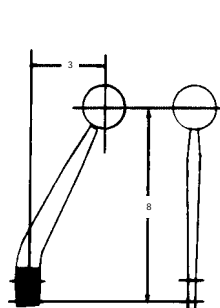

#538 0178
Used on shifters
366 0005, 391 8790

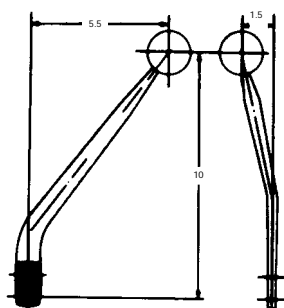

#538 0179
Used on shifters 391 4339, 366 4550

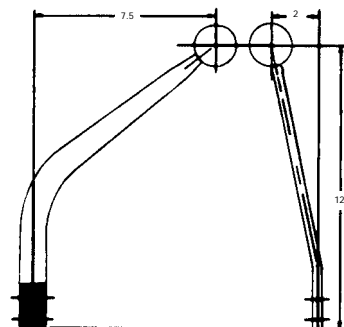

#538 0180

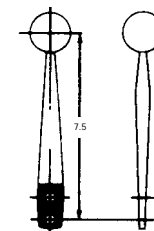

#538 0185
Used on shifters 391 7535,
391 0003, 391 7960, 491 0001

BLACK ANODIZED ALUMINUM FINISH

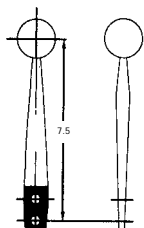

#538 0196
Used on shifters 391 0032,
391 5032, 391 5034

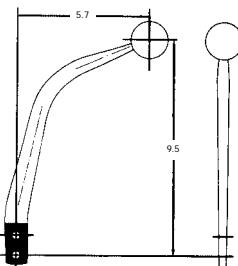

#538 0201
Used on shifter 391 0029

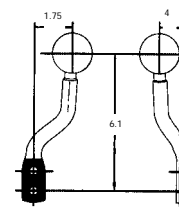

#538 0202
Used on shifter 391 0031

STEEL STICKS

Hurst steel sticks are constructed from a high strength steel and manufactured with Hurst quality.

BLACK STEEL STICKS

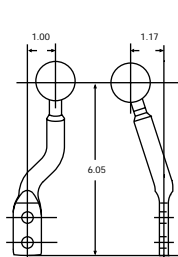

#238 5197
fits shifters 391 5030, 391 5072
12mm x 1.75 thread

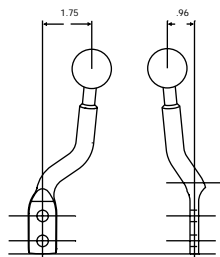

#238 5202
fits shifters 391 5031, 391 5070
12mm x 1.75 thread

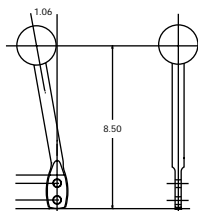

#238 8572
fits shifter 391 5060
16mm x 1.50 thread

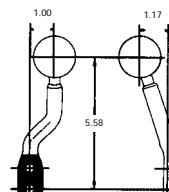

#538 0197
Used on shifters 391 0030, 391 0070
7/16-20 thread

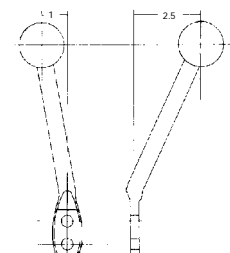

#538 8570
Used on shifter 391 0060
16mm x 1.50 thread



SHIFTER STICKS

STEEL STICKS

Hurst steel sticks are constructed from a high strength steel and manufactured with Hurst quality. Embossed with the Hurst name, all chrome-plated steel sticks incorporate a 3/8-16 thread size for use with a variety of Hurst T-Handles and shifter knobs.

CHROME-PLATED STEEL STICKS

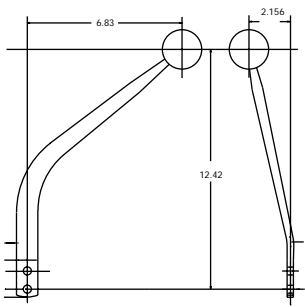

#238 0090
fits shifters 391 5040, 391 0033

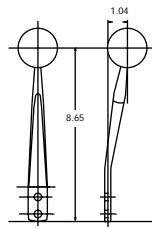

#238 0131
fits shifter 391 0028

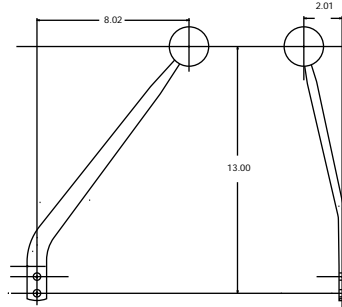

#238 0290
fits shifter 391 0110

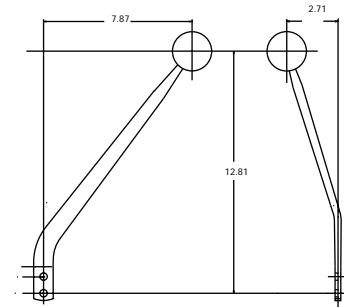

#238 0291
fits shifter 391 0120, 391 0121

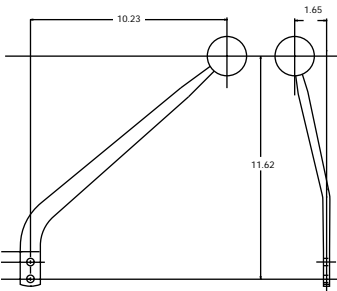

#238 0292
fits shifters 391 5050,
391 0111, 391 0155

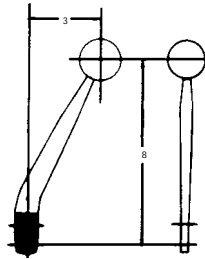

#538 0015
Used on shifters
391 8790, 366 0005

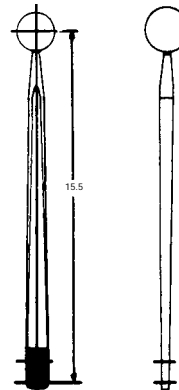

#538 0060
Used on shifter 366 0010

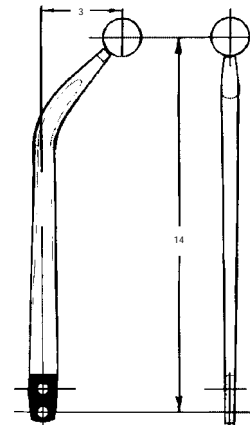

#538 0085
Used on shifter 391 0024

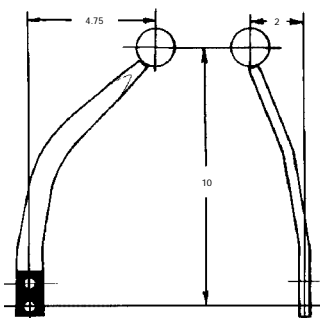

#538 0100
Used on shifter 407 0009

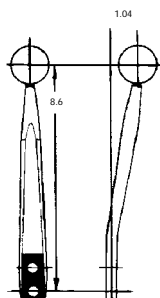

#538 0131
Used on shifter
391 0028

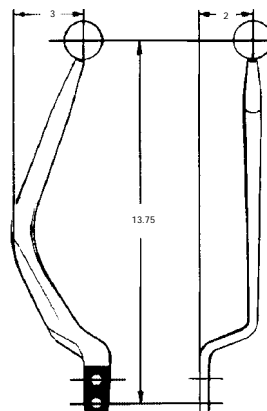

#538 0221

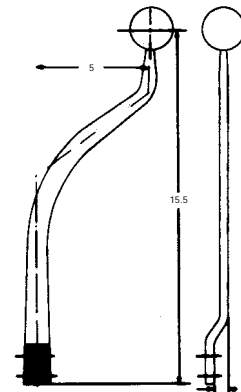

#538 4077

SHIFTER STICKS

STEEL STICKS

CHROME-PLATED STEEL STICKS

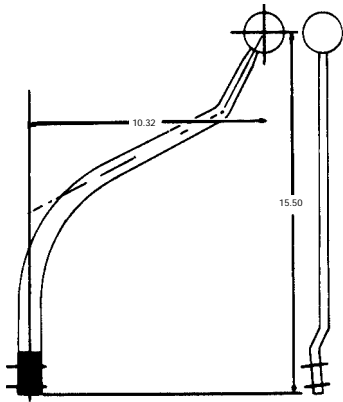

#538 4078
Used on shifter 391 6789

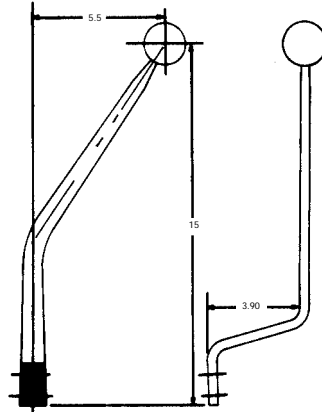

#538 4084
Used on shifter 391 6790

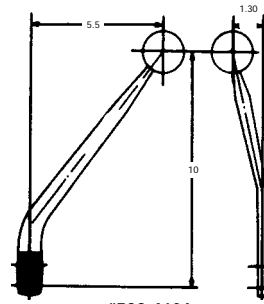

#538 4106
Used on shifters 391 4339,
391 7879, 366 4550

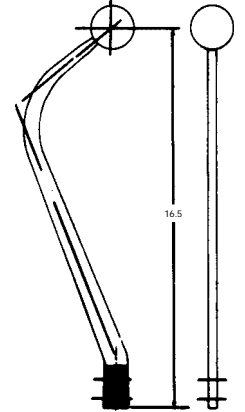

#538 4331
Used on shifters 391 0001,
391 0002, 366 6809

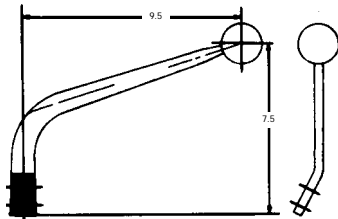

#538 6643

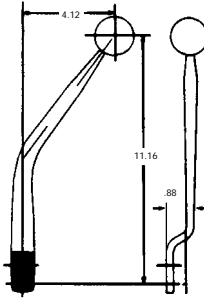

#538 6836
Used on shifters 391 6822,
391 7072, 391 6848

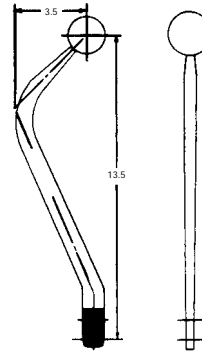

#538 6900
Used on shifters 366 6901,
391 8403, 391 8404, 391 5045

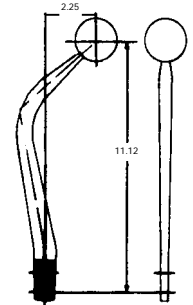

#538 7236
Used on shifters 391 7308,
391 7307, 391 7930, 366 7271

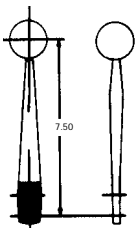

#538 7238
Used on shifters 391 7535,
391 5061, 391 7960

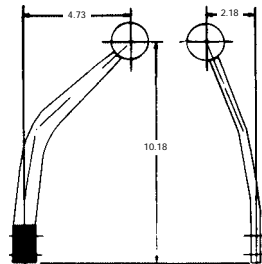

#538 7436
Used on shifters
391 7438, 366 7954

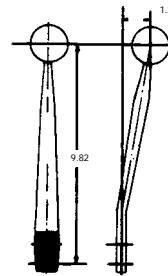

#538 7991
Used on shifter
391 7992

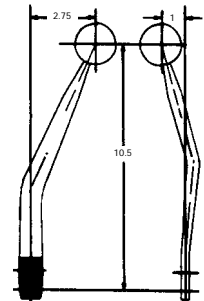

#538 8009
Used on shifters 391 8014,
391 8791, 391 8794

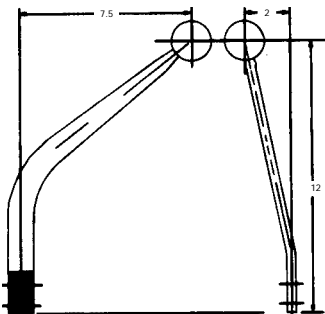

#538 8022
Used on shifter 366 8034

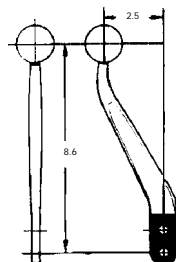

#538 8550
Used on shifter 391 0035,
391 0036, 319 0112

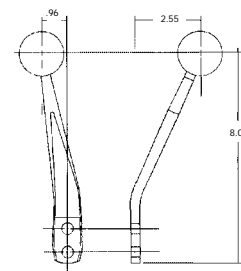

#538 8571
Used on shifter 391 0061



MANUAL SHIFTER ASSEMBLIES

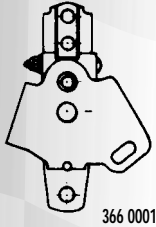

366 0001

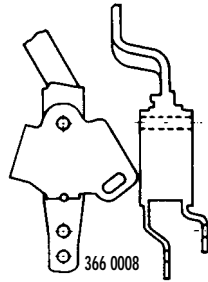

366 0008

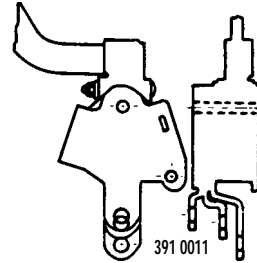

391 0011

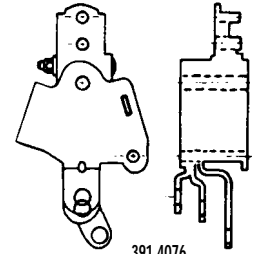

391 4076
391 7993

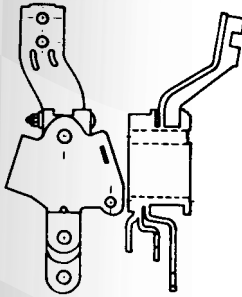

391 4340
391 6644

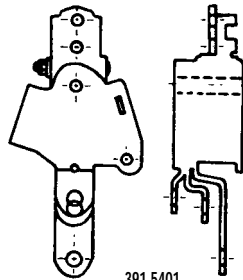

391 5401

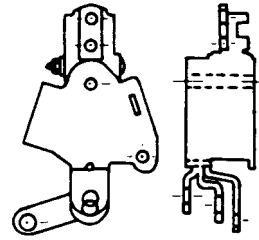

391 5405

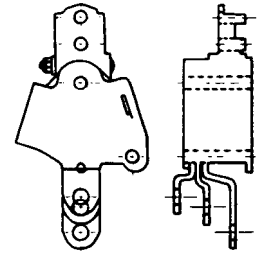

391 5043
391 6817

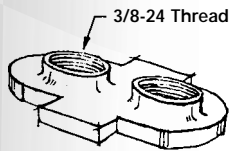
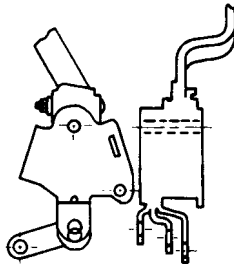
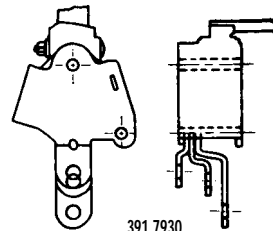

Plate Stiffener
195 0053



391 0014



391 7930

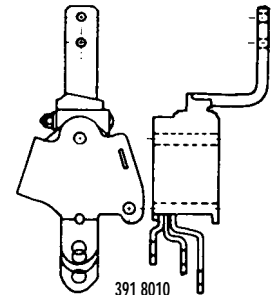

391 8010
391 8394
391 8793

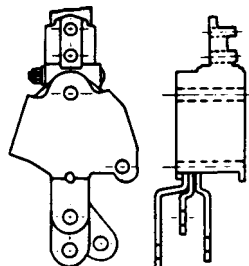

391 8787

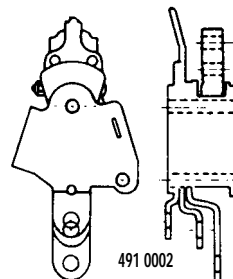

491 0002

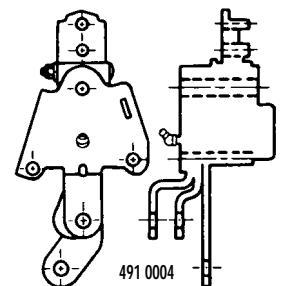

491 0004

AUTOMATIC TRANSMISSION I.D. CHART

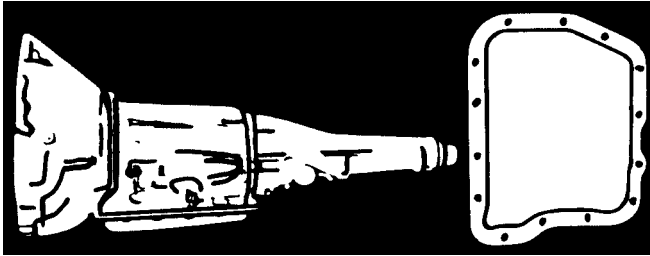

221 TORQUEFLITE 727
Chrysler Corporation 66-81

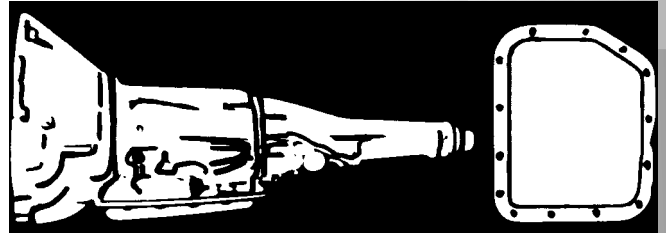

222 TORQUEFLITE 904
Chrysler Corporation 66-81

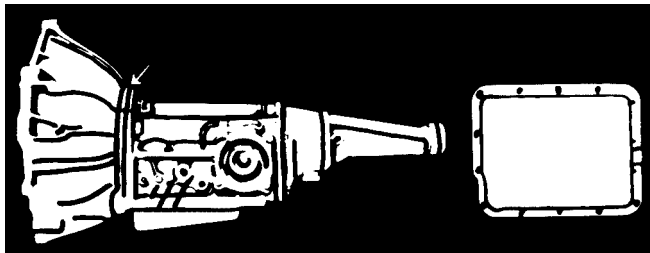

231 FORD C-4
Ford Motor Co. 64-81

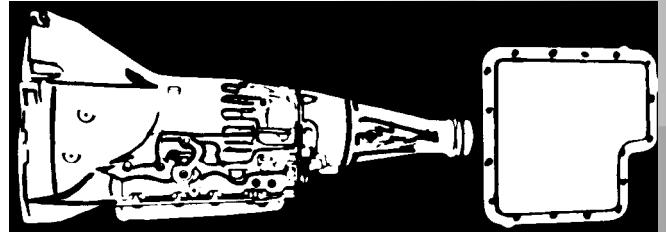

232 FORD C-6
Ford Motor Co. 66 & Later

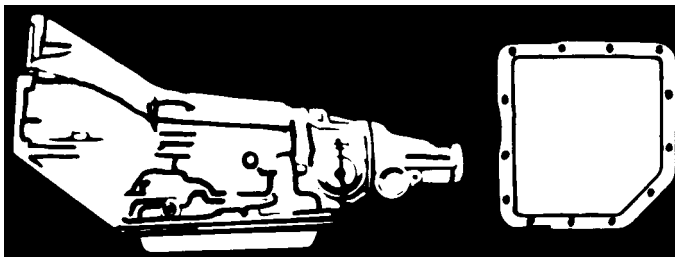

242 TURBO-HYDRAMATIC 250 & 350
General Motors 68 & Later

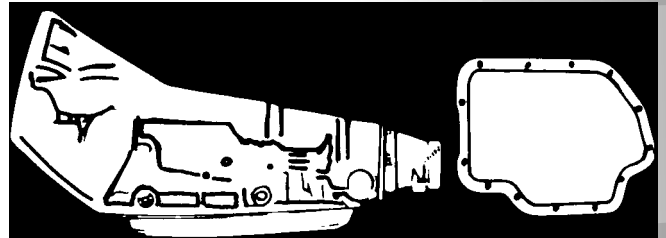

243 TURBO-HYDRAMATIC 400 & 375
General Motors 65 & Later

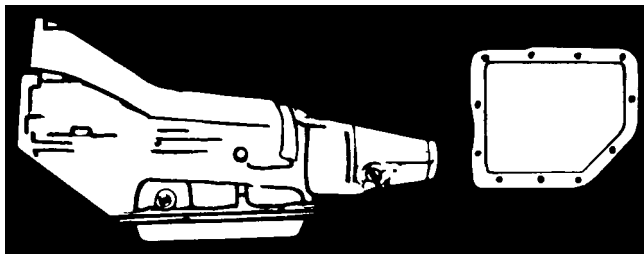

244 TURBO-HYDRAMATIC 200 (METRIC)
General Motors 76 & Later

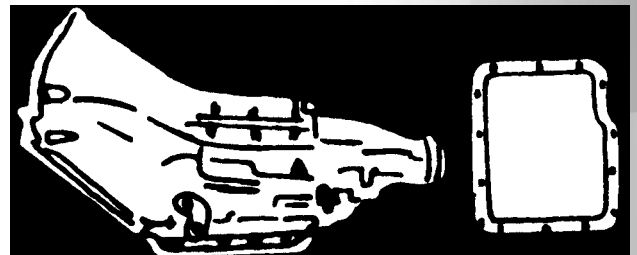

245 POWERGLIDE
General Motors 63-73

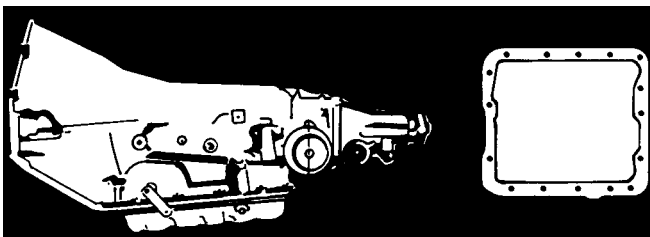

246 TURBO-HYDRAMATIC 700R4
General Motors 81 & Later

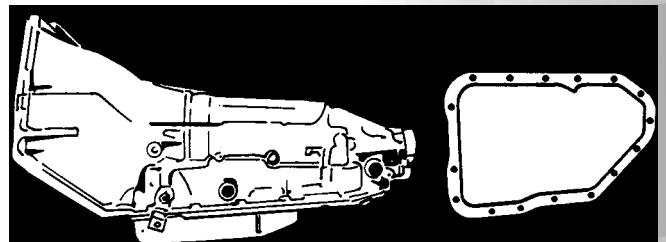

247 TURBO-HYDRAMATIC 200 4R
General Motors 81 & Later



3-SPEED TRANSMISSION I.D. CHART

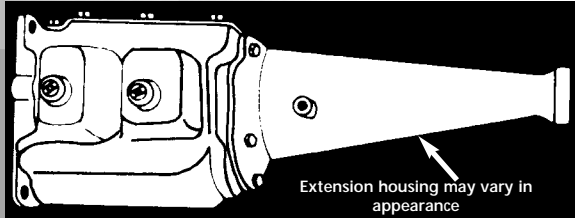

333 FORD
9 bolt top cover; first gear synchronized

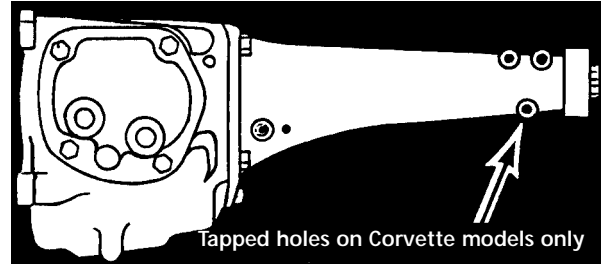

341 CHEVROLET
4 bolt side cover with round gear selection shafts

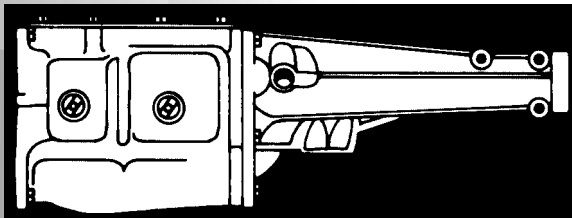

336 FORD
9 bolt top cover; first gear synchronized

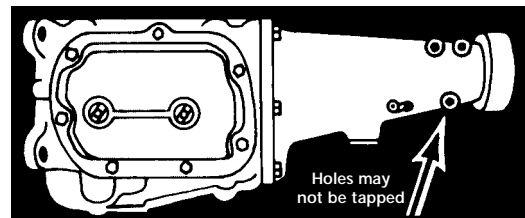

343 SAGINAW
7 bolt side cover; first gear synchronized
CAUTION: This transmission closely resembles 351 Muncie

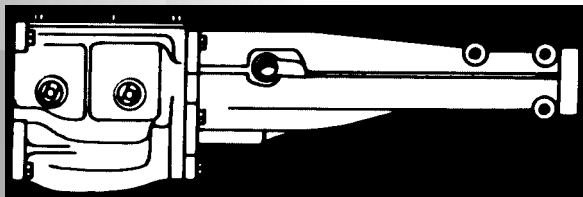

337 FORD
4 or 6 bolt top cover; first gear not synchronized

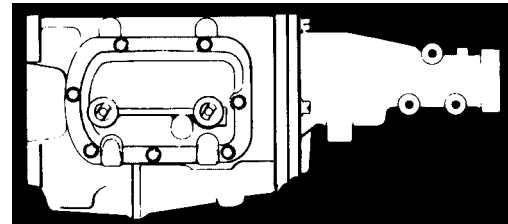

351 MUNCIE
7 bolt side cover; first gear synchronized
CAUTION: This transmission closely resembles 343 Saginaw

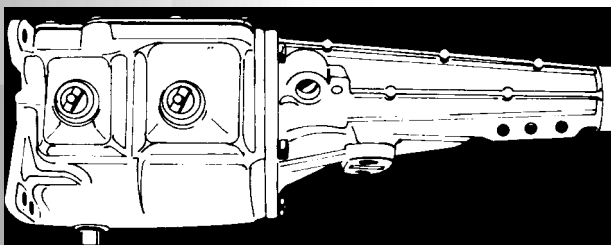

339 FORD
9 bolt top cover; first gear synchronized

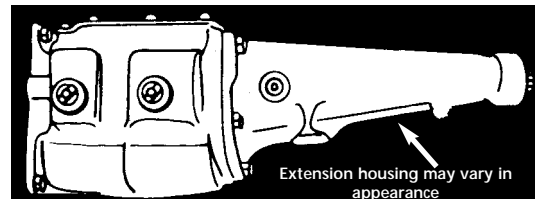

352 TREMEC
9 bolt top cover; first gear synchronized

4-SPEED TRANSMISSION I.D. CHART



Early models have only these tapped holes

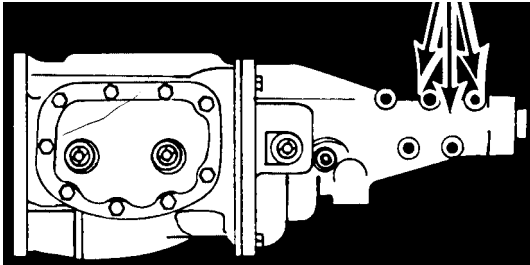

**410 BORG-WARNER T-10,
(AS-3), G. M.**
9 bolt curved bottom side cover

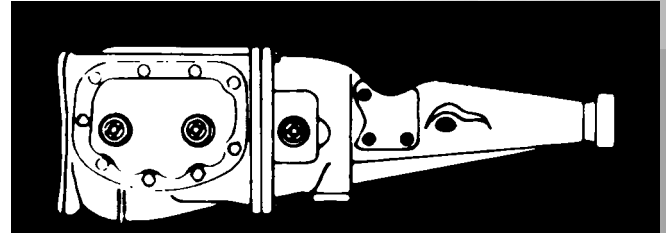

**411 BORG-WARNER T-10, SUPER T-10,
FORD/MERCURY**
9 bolt curved bottom side cover

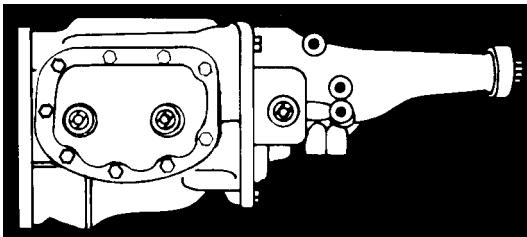

**412 BORG-WARNER T-10,
FORD/MERCURY**
9 bolt curved bottom side cover

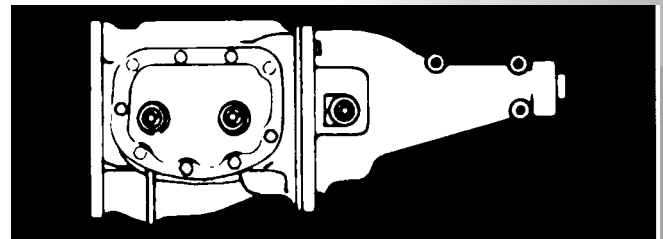

**413 BORG-WARNER T-10
FORD/MERCURY**
9 bolt curved bottom side cover

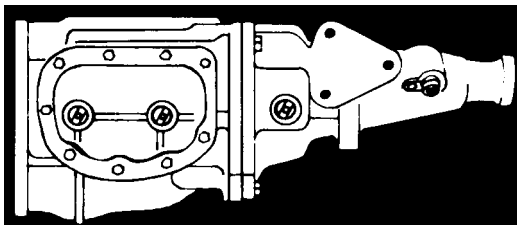

**414 BORG-WARNER T-10,
FORD/MERCURY**
9 bolt curved bottom side cover

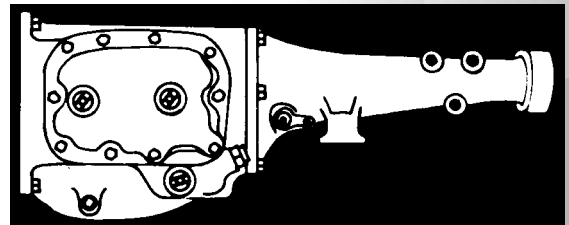

**421 NEW PROCESS, MOPAR
A-BODY**
10 bolt side cover

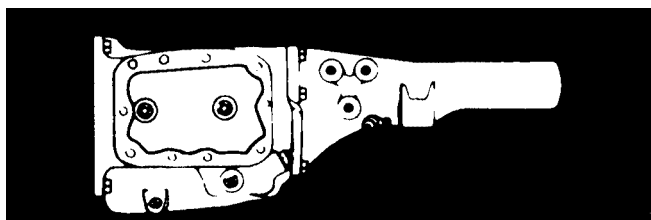

422 NEW PROCESS, MOPAR B-BODY
10 bolt side cover

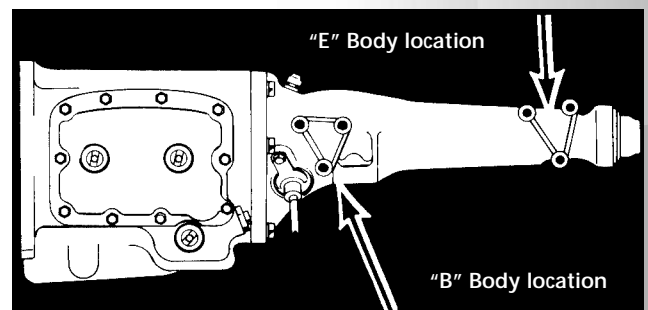

423 NEW PROCESS, MOPAR
10 bolt side cover



4-SPEED TRANSMISSION I.D. CHART

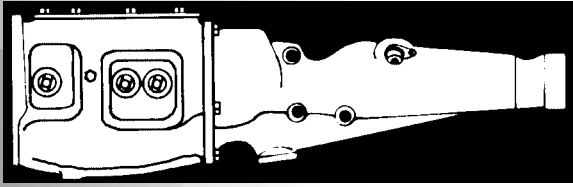

431 FORD T & C, FORD/MERCURY
10 bolt top cover

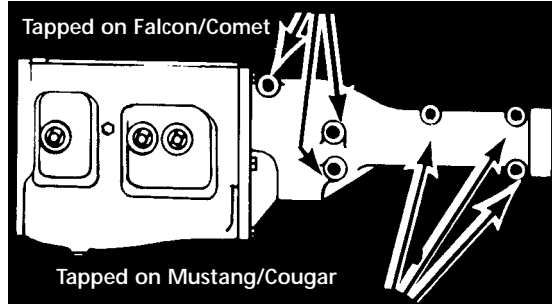

432 FORD 3+1 OVERDRIVE T & C, FORD/MERCURY
10 bolt top cover

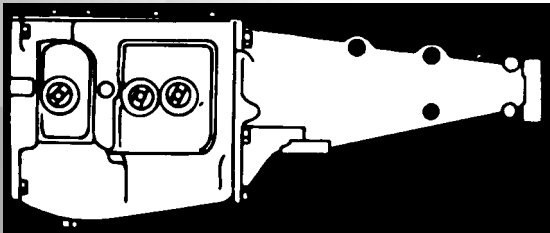

433 FORD T & C, FORD/MERCURY
10 bolt top cover

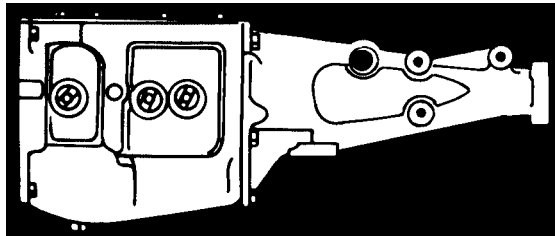

434 FORD T & C, FORD/MERCURY
10 bolt top cover

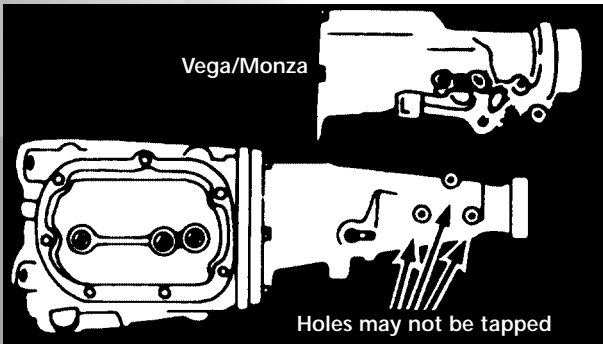

441 SAGINAW, G.M.
7 bolt side cover

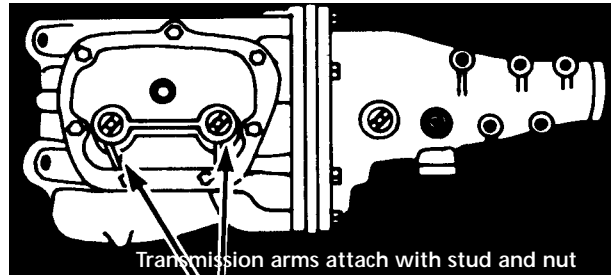

451 MUNCIE M-21 EARLY, G.M.
7 bolt side cover used from 1963-68

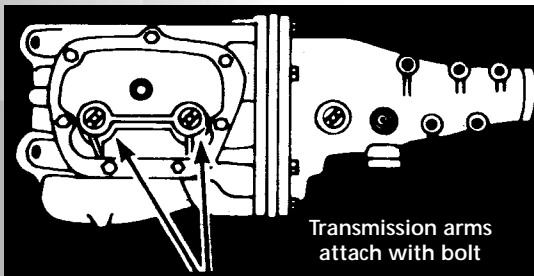

452 MUNCIE, G.M.
7 bolt side cover 1969 and later

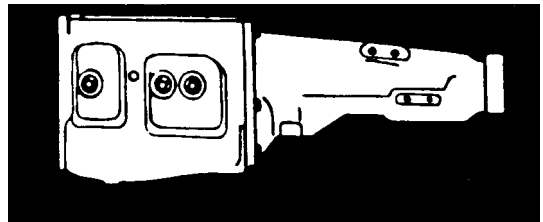

435 FORD 3+1 OVERDRIVE FORD/MERCURY

4 & 5-SPEED TRANSMISSION I.D. CHART

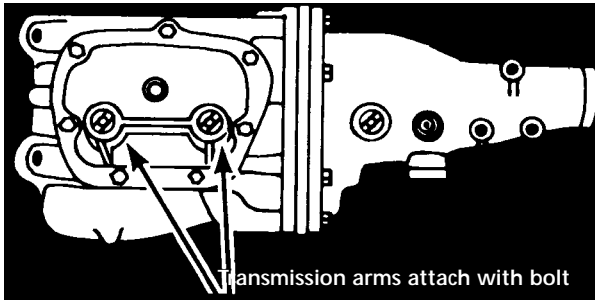

453 MUNCIE M-22
G.M. 7 bolt side cover 1970, 454 Chevelle

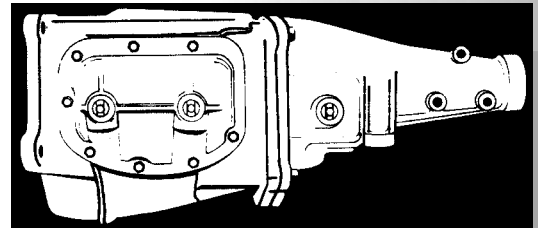

**454 RICHMOND/BORG-WARNER
SUPER T-10,**
(AS-9) 1974 and later
9 bolt curved bottom side cover

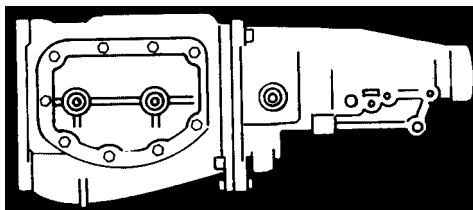

**455 BORG-WARNER TORQUE
TUBE TAILSHAFT, G.M.**
81-82 CAMARO/FIREBIRD 9 bolt side cover

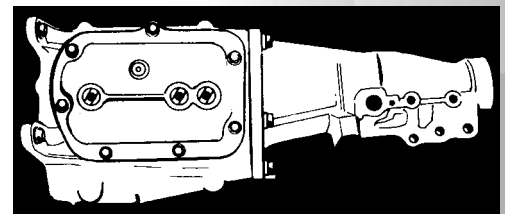

**456 SAGINAW TORQUE TUBE
TAILSHAFT, G.M.,**
81-82 CAMARO/FIREBIRD
7 bolt side cover

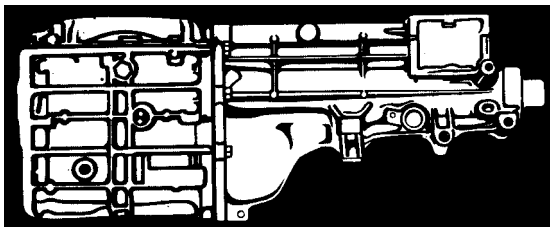

**464 BORG-WARNER T-4,
T-5 GENERAL MOTORS**
Internal Rail

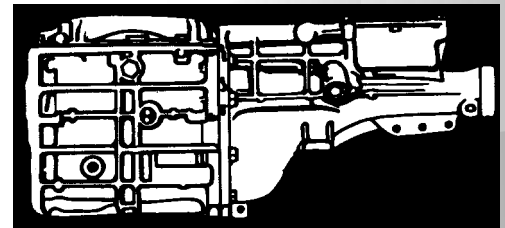

**465 BORG-WARNER
T-5, FORD**
Internal Rail

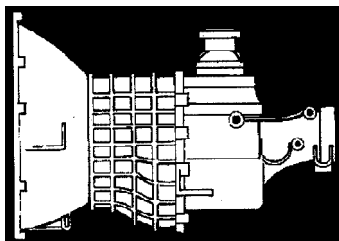

**466 NEW VENTURE
MG-5,**
G.M. & DODGE TRUCK

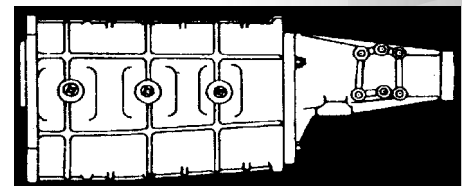

**467 RICHMOND GEAR
DOUG NASH/G-FORCE 5-SPEED**

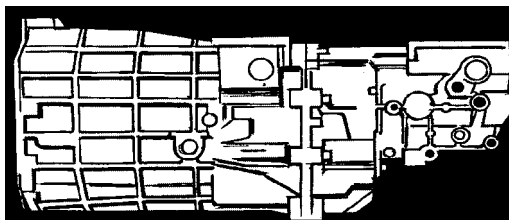

**468 BORG-WARNER
T-56, G.M.**

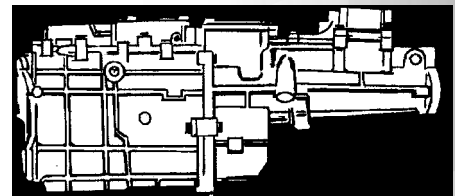

469 TREMEC 3550



PROMOTIONAL ITEMS



HURST EQUIPPED EMBLEM

Based on original HURST blueprints, this HURST EQUIPPED emblem is an authentic reproduction of the one used on the late '60's muscle cars equipped with a factory Hurst shifter. Made of durable ABS plastic with 3M adhesive tape backing for permanent mounting. Nominal size is 1-1/4" high by 5 -1/4" long. Individually packaged.
Part No. 136 1000



PERFORMANCE BANNER

Ideal for use at the races, in performance shops and on garage walls, these banners are made from heavy gauge plastic and measure approximately 3' X 6'. Designed for outdoor and indoor usage, the banners have sewn edges for additional strength and brass plated corner eyelets for easy hanging. Part No. 72666G



INDIVIDUAL BRAND DECALS

Silk screened on vinyl, these self-adhesive decals stick to any clean, dry surface.

Hurst Logo, 5-1/2" x 6-1/4" Part No. 132 0009

Mr. Gasket Logo, 5" x 1-1/4" Part No. 4

Mr. Gasket Logo, 11-1/2" x 3", contingency size Part No. 4A

Hays Logo, 5" x 8" Part No. 75-701

Lakewood Logo, 6-1/2" x 6-3/4" Part No. 60030

ACCEL Logo, 3-3/4" x 9-1/2" Part No. M23957



ASSORTED BRAND DECALS

Silk screened on vinyl, these self-adhesive decals stick to any clean, dry surface.

Assorted Mr. Gasket Performance Group Decals Part No. 7007G

PACKAGING





NUMERICAL INDEX

PART NO.PAGE	PART NO.PAGE	PART NO.PAGE	PART NO.PAGE
1050004.....40	1052140.....40, 42	1057825.....42, 43	1167153.....44
1050005.....40	1052141.....40-45	1057899.....42, 43	1170006.....44
1050007.....40	1052142.....42	1057923.....42	1170007.....44
1050008.....40	1052320.....44	1058000.....45	1170037.....40, 41
1050009.....40	1052440.....42, 43	1058006.....45	1170038.....40, 41
1050011.....40	1052441.....42, 43	1058016.....45	1170044.....44
1050012.....40	1052442.....42	1058025.....45	1170045.....44
1050016.....40, 43	1052445.....42, 43	1058026.....45	1170061.....44
1050023.....45	1052488.....42	1058027.....45	1170062.....44
1050024.....45	1052489.....42	1058028.....45	1170071.....44
1050028.....43	1052656.....42	1058029.....45	1170084.....40, 43
1050031.....44	1052723.....42	1058030.....45	1170092.....40
1050032.....44	1052724.....42	1058031.....45	1170094.....40, 41
1050035.....44	1052725.....42	1058032.....45	1170095.....41
1050036.....44	1053665.....42	1058038.....45	1170096.....44
1050043.....42, 45	1053666.....42	1058039.....45	1170097.....44
1050044.....42	1053667.....42, 43	1058040.....45	1170098.....41
1050049.....43	1053698.....42	1058041.....45	1170099.....41
1050052.....40, 43	1053831.....42	1058383.....40-45	1170144.....40
1050053.....45	1053832.....40, 43	1058559.....41	1170145.....40
1050054.....44	1053894.....40-43	1058561.....41	1170151.....44
1050055.....40, 43	1054293.....40-43	1058564.....41	1170158.....43
1050056.....44	1054294.....40-43	1058566.....41	1170199.....41
1050057.....44	1054295.....42, 43	1058567.....41	1170212.....40
1050058.....44	1054346.....42	1058572.....41	1174208.....42, 43
1050059.....11, 41	1054347.....42	1058573.....45	1174768.....40
1050070.....43	1054746.....44	1058574.....45	1174773.....40
1050073.....43	1054747.....44	1140010.....36	1174777.....44
1050074.....44	1054828.....45	1140024.....36	1174778Z.....40, 41
1050080.....40, 41	1054829.....40, 43	1141653.....36	1174819.....45
1050081.....40, 41	1054864.....42, 44	1144580.....36	1175284.....42
1050082.....40, 41	1054865.....44	1145001.....36	1175711.....40
1050084.....41	1055286.....42	1147336.....36	1176889.....42, 43
1050085.....45	1055287.....42	1147494.....36	1177154.....44
1050086.....45	1057000.....41	1148280.....44	1178227.....44
1050087.....45	1057058.....40-45	1148429.....36	1178228.....44
1050089.....44	1057059.....42	1148435.....36	1178557.....41
1050090.....44	1057060.....40-45	1148550.....41	1178558.....41
1050093.....45	1057061.....43	1148572.....41	1178560.....41
1050094.....45	1057075.....40-45	1160001.....40	1178562.....41
1050095.....45	1057128.....42	1160004.....44	1178563.....41
1050098.....41	1057129.....42, 43	1160007.....44	1178565.....41
1051526.....44	1057130.....42-44	1160010.....40, 43	1178580.....2,3
1051550.....44	1057135.....44	1160016.....44	1190002.....46
1051573.....44	1057144.....44	1160017.....44	1198057PO.....46
1051657.....44	1057645.....44	1160021.....44	1198060.....46
1051670.....42	1057646.....42	1160025.....44	1260015.....44
1051779.....44	1057647.....40-43	1161734.....44	1263705.....46
1052108.....42, 44	1057656.....44	1162319.....44	1290003.....40

NUMERICAL INDEX



PART NO.PAGE	PART NO.PAGE	PART NO.PAGE	PART NO.PAGE
1290009.....40	1540121.....45	1550033.....37	1590464.....42
1298554.....41	1540128.....40	1550036.....37	1590598.....42
1300041.....7, 41	1540130.....44	1550100.....11	1590676.....42
1300055.....7	1540131.....42	1550120.....11	1590765.....42
1300056.....7	1540136.....40	1570126.....40	1590796.....42
1320009.....56	1540137.....40	1590003.....44	1590801.....42
1340003.....44	1540150.....43	1590014.....44	1590802.....42
1340004.....44	1540162.....42	1590017.....44	1590812.....42
1361000.....33, 56	1540163.....42	1590020.....44	1590813.....42
1400009.....40	1540171.....44	1590022.....40	1590822.....42
1400020.....41	1540173.....44	1590061.....43	1590823.....42
1530003.....33, 34	1540174.....42	1590063.....44	1590876.....40
1530006.....33, 34	1540176.....40	1590070.....43	1590925.....43
1530018.....35	1540178.....42	1590075.....43	1590927.....44
1530019.....35	1540182.....45	1590083.....43	1590938.....43
1530026.....34	1540189.....40	1590089.....43	1590981.....42, 43
1530027.....34	1543151.....42	1590100.....44	1590997.....42
1530032.....35	1543152.....42	1590101.....44	1590998.....41
1530033.....35	1543153.....42	1590110.....44	1590999.....41
1534758.....34	1543154.....42	1590120.....43	1591003.....42
1534813.....34, 40	1543183.....42	1590125.....40	1591004.....41
1534900.....34	1543398.....46	1590126.....40	1591008.....45
1534910.....33, 34	1544088.....42	1590127.....40	1591009.....41
1534950.....34	1544097.....42, 43	1590128.....40	1591018.....41
1534960.....33, 34	1544242.....42	1590129.....40	1591032.....41
1538430.....35	1544353.....42	1590135.....43	1591034.....40
1538500.....34	1545289.....42	1590136.....43	1591042.....42
1538501.....34	1546821.....42, 43	1590137.....43	1598164.....45
1538510.....7, 33	1547813.....40, 43	1590139.....43	1598165.....45
1540002.....40	1547922.....42, 43	1590141.....45	1598171.....45
1540009.....44	1548006.....40, 43	1590144.....45	1598172.....45
1540010.....44	1548164.....45	1590147.....45	1598174.....45
1540013.....44	1548165.....45	1590155.....40	1598175.....45
1540016.....44	1548171.....45	1590156.....44	1598180.....45
1540024.....44	1548172.....45	1590166.....44	1598182.....45
1540025.....44	1548174.....45	1590168.....42	1598188.....45
1540053.....44	1548175.....45	1590177.....45	1598190.....45
1540061.....43	1548180.....45	1590181.....42	1598193.....45
1540070.....43	1548182.....45	1590269.....42	1613706.....46
1540071.....42-44	1548188.....45	1590274.....42	1630002.....34
1540073.....42	1548190.....45	1590279.....42	1630003.....34
1540076.....44	1548193.....45	1590307.....42	1630004.....34
1540081.....43	1548374.....40, 43	1590344.....42	1630008.....34
1540095.....44	1548390.....40	1590375.....42	1630014.....34
1540109.....45	1550010.....37	1590381.....42	1630016.....34
1540110.....40	1550015.....37	1590391.....42	1630022.....34
1540116.....40, 43	1550020.....37	1590412.....42	1630025.....34
1540117.....45	1550025.....37	1590425.....42	1630034.....44
1540119.....45	1550030.....37	1590463.....42	1630037.....34



NUMERICAL INDEX

PART NO.PAGE	PART NO.PAGE	PART NO.PAGE	PART NO.PAGE
1630038.....34	1950222.....45	2130100.....45	2132139.....42, 43
1630049.....33, 34	1950225.....7	2130101.....45	2132144.....42
1630050.....7, 33	1952298.....40, 43	2130105.....45	2132145.....42, 43
1630061.....34	1952482.....42	2130106.....45	2132146.....42, 43
1630062.....34	1952722.....42	2130110.....45	2132321.....44
1630102.....34	1952816.....42	2130135.....42	2132322.....44, 45
1630103.....34	1953176.....42, 44	2130136.....42	2132438.....42
1630104.....34	1954120.....42	2130137.....42	2132439.....42
1630108.....34	1954204.....42	2130143.....45	2132444.....42
1630114.....34	1954319.....43	2130144.....45	2132485.....42
1630116.....34	1954345.....42	2130145.....45	2132486.....42
1630140.....34	1956348.....42	2130147.....44	2132487.....42
1631036.....34	1956834.....42	2130151.....43	2132726.....42
1631037.....34	1957773.....42	2130152.....43	2132727.....42
1632002.....35	1958008.....42, 43	2130153.....43	2132728.....42
1632004.....35	1958382.....40, 43	2130161.....44	2132758.....42, 44
1632006.....35	1958551.....41	2130162.....44	2132774.....42
1632008.....35	1958574.....41	2130163.....42	2132814.....42
1632012.....35	1958657.....45	2130164.....42	2132815.....42, 43
1632014.....35	1958819.....42	2130165.....42	2132920.....42, 43
1632025.....35	1959026.....45	2130169.....44	2133172.....42, 44
1633627.....34	1959034.....45	2130171.....44	2133189.....42
1635050.....35	1959037.....45	2130173.....44	2133207.....42
1635055.....35	1959038.....45	2130175.....44	2133404.....42
1637200.....34, 40	1959044.....45	2130177.....44	2133601.....44
1637624.....34	1959045.....45	2130189.....44	2133646.....42, 43
1637626.....34	2130002.....40	2130190.....40	2133691.....42
1660002.....40	2130003.....40	2130192.....40	2133695.....42
1690005.....41	2130011.....40	2130193.....42	2133830.....42
1690006.....41	2130012.....40	2130194.....42	2134093.....44
1710016.....44	2130024.....44	2130195.....42	2134147.....42, 43
1745000.....32	2130025.....44	2130197.....45	2134164.....42
1801000.....39	2130030.....43	2130198.....45	2134187.....42, 43
1890070.....44	2130037.....40, 43	2130200.....45	2134188.....42, 43
1890071.....44	2130038.....40, 43	2130205.....45	2134209.....44
1890082.....7	2130039.....40, 43	2130206.....45	2134210.....44
1950037.....40, 43	2130046.....43	2130209.....40	2134335.....42, 43
1950053.....50	2130058.....44	2130214.....40	2134348.....42
1950122.....40	2130062.....44	2131562.....44	2134646.....43
1950125.....42	2130063.....44	2131588.....40-44	2134741.....44
1950133.....45	2130066.....44	2131699.....40, 43	2134742.....44
1950140.....40	2130071.....45	2131720.....42	2134769.....42, 43
1950148.....43	2130072.....45	2131735.....44	2135298.....42, 43
1950163.....42, 43	2130078.....43	2131736.....44	2135299.....42, 43
1950164.....42	2130079.....40, 43	2132001.....44	2135307.....42, 43
1950165.....42, 43	2130080.....44	2132007.....44	2135308.....42
1950167.....44	2130084.....45	2132008.....44	2136100.....45
1950168.....44	2130089.....44	2132137.....42, 43	2136102.....45
1950199.....42	2130096.....45	2132138.....42	2136103.....45

NUMERICAL INDEX



PART NO.PAGE	PART NO.PAGE	PART NO.PAGE	PART NO.PAGE
2136104.....45	2418570.....41	3162025.....6	3734089.....15, 17
2136106.....45	2418571.....41	3162030.....5	3734297.....14, 15
2136109.....45	2480003.....11, 40	3320001.....46	3734354.....14
2136110.....45	2480021.....41	3320002.....46	3734529.....14, 17
2136111.....45	2483875.....32, 33	3321000.....22	3734531.....14, 17
2136112.....45	2483880.....33	3321002.....22	3734648.....14
2136113.....45	2488600.....7	3321657.....46	3734734.....14, 18
2136117.....45	2488601.....7	3327302.....46	3735587.....15-17
2136118.....45	2488605.....11	3570028.....44	3737131.....14
2136120.....45	2654388.....43, 44	3570029.....44	3737437.....14, 17
2136123.....45	2655293.....43	3591000.....11	3737637.....15, 16
2136124.....45	2800001.....46	3660001.....44, 50	3737638.....15, 16
2136125.....45	2807186.....46	3660008.....44, 50	3737834.....14-18
2136126.....45	2854470.....39	3660014.....21	3737897.....14-17
2136127.....45	2858601.....38	3663179.....21	3737919.....14-18
2136134.....45	2858602.....38	3666809.....21, 44	3738164.....26
2136135.....45	2858611.....38	3666901.....21, 44	3738165.....26
2136162.....45	2858612.....38	3667271.....21, 44	3738171.....26
2136163.....45	2858630.....38	3670006.....21	3738172.....26
2136164.....45	2858640.....38	3670010.....21	3738174.....26
2136818.....42, 43	2858660.....38	3670013.....21	3738175.....26
2137803.....40, 43	2920000.....9	3670014.....21	3738180.....26
2137819.....40, 43	2920001.....9	3670023.....21	3738182.....26
2138003.....40, 43	2920003.....40	3670025.....21	3738188.....26
2138037.....40, 43	2920004.....40	3670027.....21	3738190.....26
2138377.....40, 43	2920006.....9	3673111.....21	3738193.....26
2138378.....40, 43	2920007.....9	3673112.....21	3738605.....14
2138379.....40, 43	3078576.....41	3673122.....21	3738607.....14
2138697.....45	3160001.....4	3677143.....21	3738609.....14-18
2138698.....45	3160003.....41	3677640.....21	3738611.....14
2260020.....5	3160006.....4	3730006.....27	3738615.....19
2288397.....43	3160008.....41	3730007.....27	3738616.....19
2305000.....41, 46	3160009.....4	3730011.....27	3738617.....19
2308500.....41, 46	3160011.....41	3730014.....27	3738618.....19
2380077.....40	3160014.....4	3730017.....14-17	3738620.....16
2380090.....48	3160016.....4	3730018.....44	3738621.....14
2380131.....48	3160017.....41	3730019.....44	3830005.....40
2380290.....48	3160018.....41	3730020.....44	3830012.....8
2380291.....48	3160020.....6	3730021.....14, 17	3835680.....10
2380292.....48	3160021.....41	3730022.....14, 17	3835681.....10
2385197.....47	3160025.....6	3730024.....31	3835690.....10
2385202.....47	3160026.....41	3730025.....31	3835691.....10
2388572.....47	3160030.....4	3733157.....14, 15	3838500.....2
2410002.....40	3160088.....41	3733162.....14	3838504.....2
2410003.....40	3162001.....5	3733163.....14-18	3838505.....2
2410004.....40	3162006.....5	3733164.....15, 16	3838510.....2
2418552.....41	3162009.....5	3733166.....15, 16	3838511.....2
2418553.....41	3162014.....5	3733167.....15, 16	3838515.....3
2418567.....41	3162020.....6	3733668.....15-17	3838520.....3



NUMERICAL INDEX

PART NO.PAGE	PART NO.PAGE	PART NO.PAGE	PART NO.PAGE
38385213	391400022	391878743	538019743, 47
38385253	391400222	391878915, 16	538020143, 47
384000230	391400422	391879114, 17	538020243, 47
384000330	391400622	391879243	538022148
384000444	391400822	391879343, 50	538029043
384000544	391401522	391879414-17	538029143
384000630	391402522	391879750	538100045
384000744	391403022	407000928	538407748
384001230	391407643, 50	407001045	538407843, 49
384001330	391433914, 17	407001528	538408449
384001444	391434043, 50	411815626	538410643, 49
384001544	391502012, 16	411815726	538433143, 49
384001630	391502112, 16	491000127	538664349
384001744	391502512, 16	491000245	538683643, 49
384002230	391503012, 16	491000250	538690044, 49
384002330	391503112, 16	491000431, 50	538723643, 49
391000115-18	391503212, 14	491001031	538723843, 45
391000215, 18	391503512, 16	500002046	538743643, 49
391001143, 50	391504012, 16	500002346	538799143, 49
391001443, 50	391504212, 16	500002446	538800943, 49
391002416	391504350	500002540, 46	538802249
391002814	391504512, 16	500002846	538855043, 49
391002915, 18	391505012, 15	500002946	538857043, 47
391003016	391506012, 17	500855541, 46	538857143, 49
391003116	391506112, 17	501000225	550000139
391003315, 18	391507012, 16	501000440	550000239
391003516	391507212, 16	501001624	566755032
391003616	391508412, 14	501001740	567150032
391003743	391508512, 14	501001825	567151032
391003843	391540143, 50	503002440	567151532
391003945	391540343	503003023	567151632
391004043	391540543, 50	503003123	650000111
391004143	391664450	503003223	456
391005143	391678915, 17	503003323	4A56
391005643	391681743, 50	506000124	7007G56
391005743	391682243	506000340	M2395756
391006943	391684814-17	538001548	6003056
391007016	391730714, 15	538003516, 17	72666G56
391011015, 18	391730814-17	538003616, 17	75-70156
391011115, 18	391743814, 17	538006043, 48	
391011215, 18	391753514, 19	538008544, 48	
391011315, 18	391787943	538009043	
391011943	391793014, 43	538010048	
391012015, 18	391796014, 17	538013143, 48	
391012115, 18	391799214, 43	538017847	
391013116	391799350	538017947	
391015515, 18	391801043, 50	538018047	
391318015-17	391801414, 15	538018547	
391378014, 43	391839443, 50	538019643, 47	

Acknowledgements

A sincere "Thank You" is extended to everyone who worked on this catalog, especially Andrea Thompson, Sheryl Pritt, Kirk Tenney, Jim Puskas and Mike Stasko.

MR. GASKET PERFORMANCE GROUP



Hurst is one of the seven premier brands of the Mr. Gasket Performance Group. Be sure to specify the brand names listed below to insure quality, reliability and value for all of your performance and custom needs.



ACCEL offers a wide range of performance ignition products including digital fuel injection systems, fuel injectors, coils, distributors, caps, rotors, ignition wires and spark plugs.

Erson manufactures a complete line of camshafts and valve train components ranging from street to strip applications, including FSP valve springs, push rods and roller rocker arms.

Hays builds a wide range of high performance clutches for street and strip applications including pressure plates, discs, flywheels and complete clutch kits. Hays also has a complete line of custom-built specialty clutches for drag racing and tractor-pulling applications.

Hurst is the leading manufacturer of racing shifters for both manual and automatic transmission applications. Hurst also has a wide range of shifter accessories including the Original Roll/Control.

Lakewood manufactures safety and suspension products including hydroformed bellhousings, traction bars, drag shocks and lowering springs.

Mallory manufactures a complete line of high performance racing ignition and fuel systems, including ignition boxes, distributors, magnetos, ignition wires, caps, rotors, fuel pumps and regulators.

Mr. Gasket has an extensive line of high performance parts and accessories including gaskets, fasteners, chrome plated accessories, engine components, carburetor adapters and spacers, cooling system products, suspension components and fuel system accessories.

LOCAL DEALER 1-888-MRGASKET

To find your local Hurst dealer, call 1-888-MRGASKET, visit our web site at www.mrgasket.com or look in the Yellow Pages under Automobile Performance, Racing & Sports Car Equipment.

INTERNET www.mrgasket.com

Hurst has an extensive internet presence which includes a new interactive catalog, new product listings, frequently asked questions, tech tips, and installation instructions.



WARRANTY

HURST SHIFTER MECHANISM WARRANTY Limited "For as Long as You Own Your Vehicle" Warranty

Hurst Performance division of Mr. Gasket Inc. warrants to original purchaser ("You" or "Your") that its shifter mechanism will be free from defects in material and workmanship from the date the shifter is first installed in a vehicle you own (the "original vehicle") for as long as you continue to own the original vehicle provided the shifter is properly installed and used under normal operating conditions. To be eligible for this Limited Warranty, the Product Registration Card should be completed and sent to Hurst Performance within thirty (30) days after the purchase of your shifter. If a Hurst shifter is found to be defective, it will be repaired or exchanged at Hurst's option without charge. This warranty does not cover damage caused by misuse, alteration, negligence or excess wear. All implied warranties, including, but not limited to the implied warranties of fitness for a particular purpose and merchantability, are limited in duration to a period ending with the period of the corresponding express limited "For as Long as You Own Your Vehicle" warranty set forth above.

Under no circumstances will Hurst Performance be responsible for incidental or consequential damage arising from, or in connection with, the installation or use of any Hurst product. NOTE: This warranty does not apply to any Hurst shifter mechanism purchased before June 1, 1994, nor does it apply to any Indy Three Speed Shifter Mechanism. Some states do not allow limitations on how long an implied Warranty lasts or do not allow for the exclusion or limitation of incidental or consequential damages so the above limitations may not apply to you. This warranty gives you specific legal rights, and you may also have other rights which vary from state to state. Return of the Product Registration Card is not a condition precedent to warranty coverage.

**SHIP IT PREPAID TO: HURST PERFORMANCE, WARRANTY SERVICE DEPT
550 MALLORY WAY, CARSON CITY, NV 89701**

LIMITED WARRANTY

WHAT IS COVERED: All parts which are defective in materials or workmanship, subject to the following:

WHAT IS NOT COVERED: (1) Products which have been subjected to abuse, accident, alteration, modification, improper installation, tampering, negligence, misuse, or if repaired or serviced by anyone other than a service facility authorized by Hurst Shifter to render such service; (2) Operational adjustments or procedures covered in the instruction/installation material, if any; (3) Actual or alleged labor, transportation, or other incidental charges; (4) Actual or alleged consequential damages incurred by use of this product.

WHO IS COVERED: The original purchaser, at retail.

WHAT WE WILL DO: Hurst Performance, at its election, will for a period of ninety (90) days from the date of original retail purchase, either repair or replace all defective parts free of charge or refund the purchase price for the defective product.

WHAT YOU MUST DO FOR WARRANTY SERVICE: In the event that the original retail purchaser detects a defect in the material or workmanship, the product(s) in question must be returned by the original retail purchaser to the place of original purchase for warranty determination. In the event that the purchaser does not receive satisfaction from the place of original purchase or in the event there are any questions with regard to this limited warranty, please write the Technical Service Department, Hurst Performance, 10601 Memphis Avenue, Cleveland, Ohio 44144, or call (216) 688-8300 and ask for Technical Service. Do not send alleged defective parts to Hurst Performance without prior receipt of authorization from Hurst Performance to do so. Upon receipt of such authorization, the original purchaser should send such part and proof of purchase, postage prepaid, to Hurst Performance, 550 Mallory Way, Carson City, NV 89701.

HURST PERFORMANCE MAKES NO EXPRESS WARRANTY AS TO THIS PRODUCT OTHER THAN THE LIMITED WARRANTY STATED HEREIN. THERE ARE NO WARRANTIES WHICH EXTEND BEYOND THE EXPRESS TERMS OF THIS LIMITED WARRANTY. HURST MAKES NO IMPLIED WARRANTIES WHATSOEVER, INCLUDING THE IMPLIED WARRANTY OF MERCHANTABILITY AND THE IMPLIED WARRANTY OF FITNESS FOR A PARTICULAR PURPOSE. HURST PERFORMANCE SHALL NOT BE LIABLE FOR ANY INCIDENTAL DAMAGES, INCLUDING THE COST OF INSPECTION, RECEIPT, TRANSPORTATION, CARE OR CUSTODY OF THIS PRODUCT, AND FOR ANY CONSEQUENTIAL DAMAGES, INCLUDING DELAY, LOSS OF INCOME OR PROFITS, OR INJURY TO PERSON OR PROPERTY, ARISING FROM ANY ACTUAL OR ALLEGED BREACH OF THIS LIMITED WARRANTY.

Some states do not allow the exclusion or limitation of incidental or consequential damages or limitations in implied warranties, so these limitations or exclusions may not apply to you. This warranty gives you specific legal rights, and you may also have other rights which vary from state to state.

Materials, components, specifications, colors, model changes, availability and prices are subject to change without notice or obligation. Manufacturers' brand names, trademarks and registered trademarks are used for reference only, and are not to imply that any product is of their manufacture or any association therewith.

Hurst Performance makes no representation or warranty that its products comply with local, State or Federal emission levels, noise levels or safety standards. The purchaser assumes all responsibility for such use and compliance.

TECHNICAL SERVICE

A highly trained Technical Service Department is maintained by Hurst Performance to answer your technical questions, provide additional product information and offer various recommendations. See your local Hurst retailer for specific prices. For best results, Technical Service calls, correspondence and warranty questions should be directed to the following address:

Hurst Performance, Attn: Hurst Technical Department, 10601 Memphis Avenue #12, Cleveland, Ohio 44144
216-688-8300 ext 500, Fax 216-688-8306 Monday - Friday 8:30 a.m. - 5:00 p.m. EST. www.mrgasket.com

SHIFTER RESTORATION



HURST SHIFTER REBUILD SERVICE

Hurst offers a rebuild service for most Hurst aftermarket and Hurst OE shifters. Hurst can rebuild your Hurst shifter and make it feel like new again. All worn parts are replaced so the shifter operates as smoothly as the day you bought it. To obtain service, send the shifter (freight prepaid) and payment with a note describing any problems to:

**Hurst Performance Shifter Rebuild Service
550 Mallory Way, Carson City, NV 89701-5374**

Include your name, shipping address and daytime phone number.

Allow 5 weeks for a shifter rebuild: 15 working days for the actual rebuild and 7 days each way for shipping. Allow an additional week for Hurst OEM shifters.

To inquire about the status of your shifter sent to Hurst for rebuilding at the above address, call 775-882-6600 ext. 342, 8 a.m. – 4 p.m. PST.

REBUILD CHARGES

The charges below cover inspection and replacement of worn parts.

Damaged, modified, missing or unusable components are extra.

Excessively rusted or damaged shifters may not be rebuildable.

MANUAL SHIFTERS

\$60.00

Billet/Plus 5 & 6-speed, Competition Plus 4, 5 & 6-speed,
Mastershift 3-speed, Street Super/Shifter 4-speed,
Super Shifter 3, V-Gate 2 In-Line Shifter

\$90.00

Hurst OEM Shifters, Lightning Rods for Lenco,
Richmond 5-speed, Speedway Super Shifter

AUTOMATIC SHIFTERS

\$35.00

Quarter Stick (all)

\$45.00

Auto/Stick (all), Dual/Gate 2, Dual/Gate OEM*,
Pro-Matics 2(all), Street Rod Shifter, V-Matics 2

\$90.00

Lightning Rods*

*CALL 775-882-6600 EXT. 342, 8 A.M.-4 P.M. PST
BEFORE SENDING SHIFTER.

Shipping & Handling Charges \$9.25
(Outside continental U.S.A. is extra.)

Call for prices on any Hurst Shifter not listed above. If not prepaid, the rebuilt shifter will be sent back to you C.O.D. plus freight charges. For faster service and to save C.O.D. charges, we accept Visa and Mastercard. For any further questions or assistance other than shifter rebuild status, contact our highly trained Technical Service Department at 216.688.8300 ext. 5, 8:30 a.m. – 5:00 p.m. EST or fax 216.688.8306 or visit our website at www.mrgasket.com.

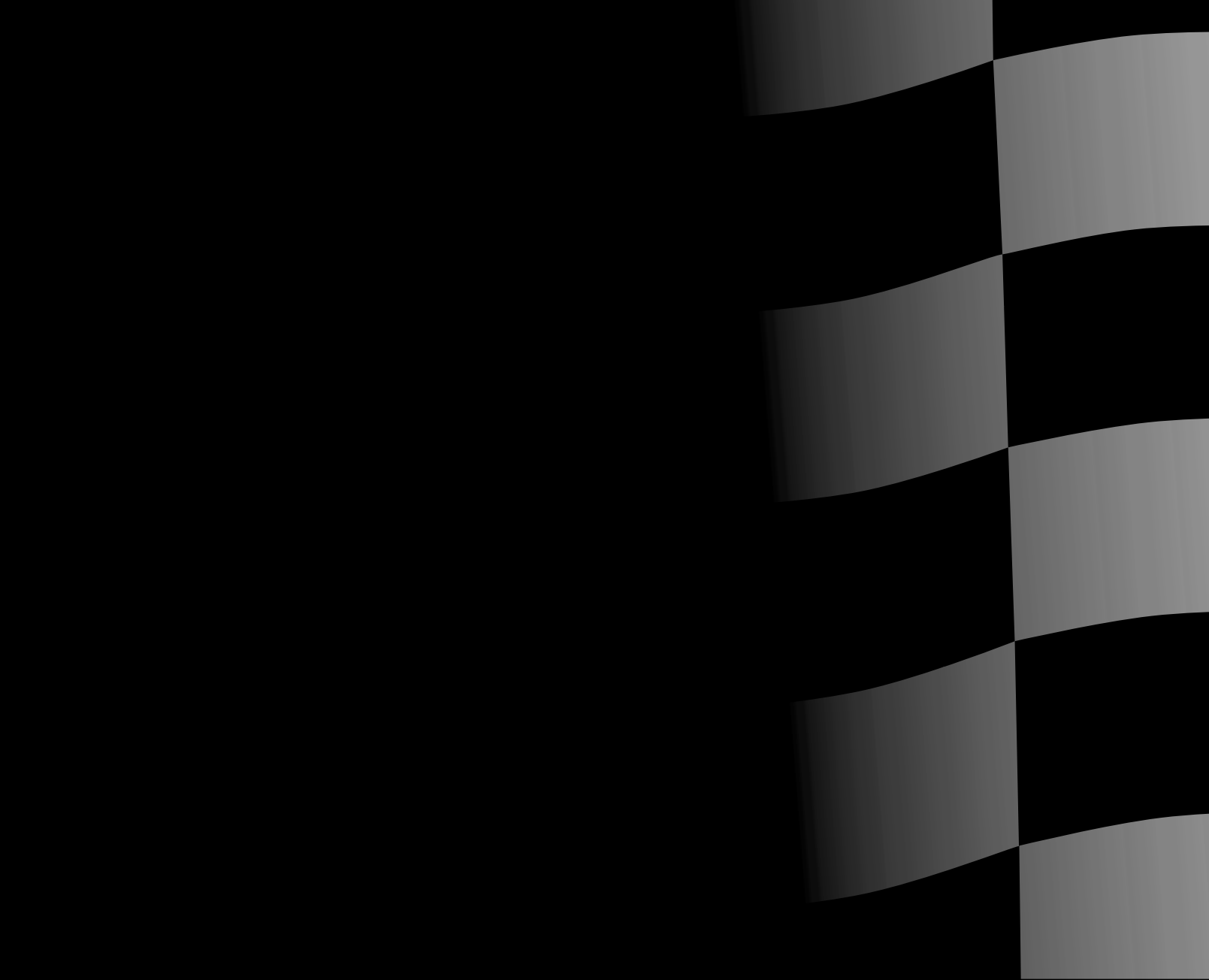

THE MR. GASKET PERFORMANCE GROUP
CLEVELAND, OHIO
www.mrgasket.com